



Brand Book

Table of Contents

Welcome	3
Strategy	4
Vision	5
Mission + Values.	6
Values.	7
Visual System Overview	8
Visual Toolkit.	9
SAI Logo.	10
Constructing the Logo	11
Primary Logo Lockup	12
Clear Space + Sizing.	13
Logo Use	14
Logo Misuse	15
Alternate Lockups	16
Alternative Lockup Use	17
Division Logos	18
Division Logo Use + Alternates	19
SAI-Division Lockups	20
Color	21
Overview	22
Core Colors.	23
Gray Palette	24

Core Color Usage	25
Tints + Shades	29
Contrast.	30
Color Use + Accessibility	31
Color Codes	32
Gradients	33
Typography.	34
Our Typefaces	35
Montserrat	36
Nunito	37
Sizing Headlines	38
Type Styling	39
Type Hierarchy.	40
Photography.	41
Overview	42
Authentic + Candid	43
Industry-Specific.	44
Scenic Accents	45
Scenic Accents in Action	46
Photo Misuse.	47
Iconography	48
Icons.	49

Graphic Elements	50
Overview	51
Graphic Elements	52
Graphic Vessels	53
In Action.	54
Patterns	55
Overview	56
Patterns.	57
In Action.	58
Illustrations.	59
Overview	60
Grids + Layouts	61
Grid System Overview	62
Layout Terms.	63
Vertical Layouts	64
Horizontal Layouts	65
Flexible Grids.	66
Sizing the Logo: Vertical Layouts	67
Sizing the Logo: Horizontal Layouts.	68
Sizing the Logo without a Grid.	69
Logo Placement	70
Type Placement	71

Welcome

Hello!

Welcome to the SAI Brand. This Brand Book is designed to guide you through the essence of who we are, what we stand for, and how we express our unique identity in everything we do.

In these pages, you'll find the principles that shape us — our values and mission that connect us with our clients, our visual identity, and our tone of voice.

From colors to fonts, from messaging to imagery, every detail is crafted to tell our story and make a lasting impression. Whether you're a team member, partner, or collaborator, this guide will help you bring the SAI brand to life with consistency and creativity.



Strategy

Improving global healthcare,
one insight at a time



Mission + Values

Mission

To empower life science companies with strategic insights to improve patient care, foster innovation, and navigate complex decisions.

Values

Driven

Caring

Collaborative

Insightful

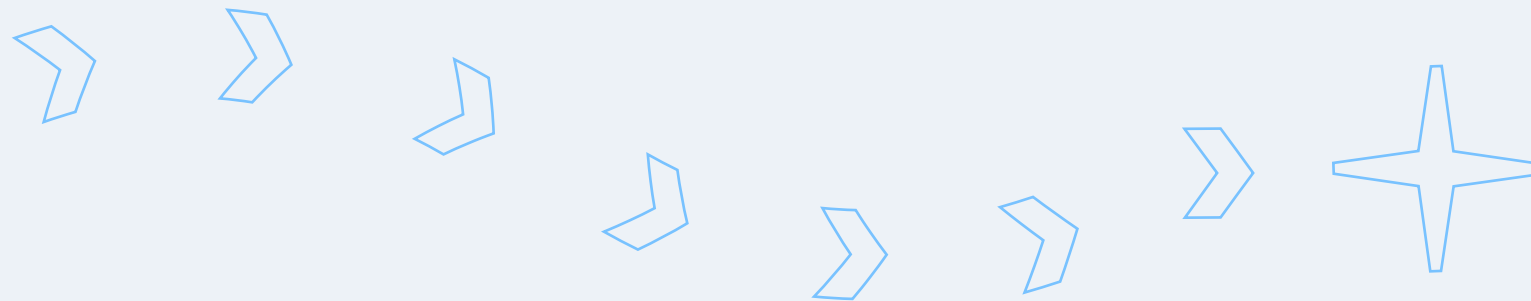

Brand Values

Driven

We consistently strive for excellence, setting high standards and pushing ourselves to meet and exceed our goals. We embrace challenges with determination and resilience, always seeking to go the extra mile for our clients and our colleagues.

Caring

We treat our clients, each other, and ourselves with respect, kindness, and compassion. We work together to create an inclusive environment where everyone is valued and heard.

Collaborative

We are stronger when we work as a team, both internally and in partnership with clients. We each take responsibility for sharing our perspective, delivering exceptional communication, and offering constructive feedback in service of making our collective work the best it can be.

Insightful

We are committed to deeply exploring the needs of our clients. We ask questions, analyze data, and use our business and therapeutic area knowledge to craft stories that help clients make the best decisions.



Visual System Overview

VISUAL SYSTEM OVERVIEW

Visual Toolkit

This visual toolkit is a reflection of the SAI brand. It has been designed with enough flexibility to meet our diverse branding needs while maintaining a strong and consistent look.

The toolkit contains the main components of our visual brand:

- Logo
- Typography
- Color palette
- Photography
- Patterns
- Icons
- Graphic elements

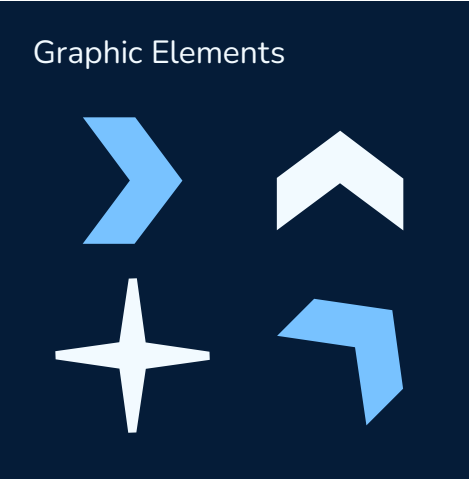
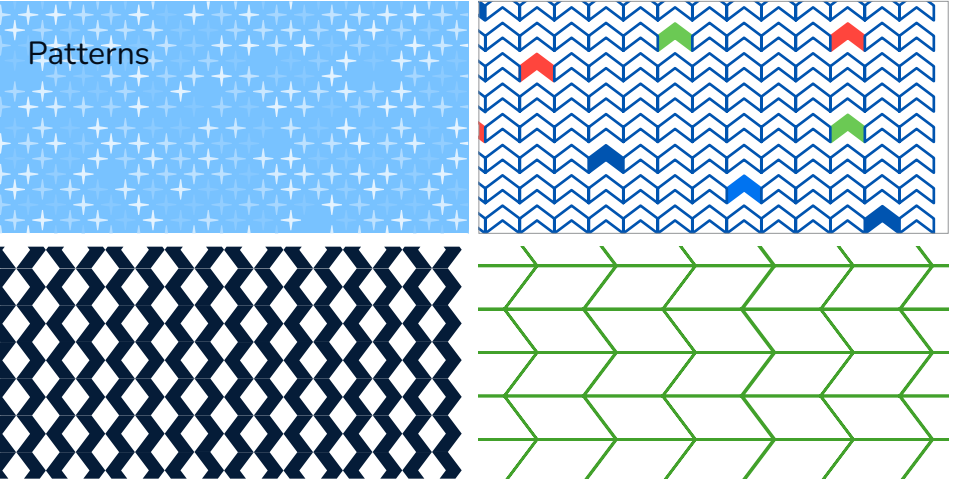



SAI Logo

SAI LOGO

Constructing the Logo

The SAI logo was constructed with our vision and mission at the forefront.

Logomark

The SAI logomark is made up of four arrows directed toward the center making a north star shape in the negative space.

Arrows represent forward momentum, strategic direction and symbolize progress, precision, and insight. Arrows in various directions convey agility, adaptability, and the ability to navigate the challenges of evolving competitive landscapes.

Stars serve as symbols of clarity and excellence and reflect moments of discovery and breakthroughs. They also evoke a sense of guidance and vision helping to illuminate the path forward.

Wordmark

The wordmark is presented in a modern, easy-to-read typeface that denotes professionalism and complements the dynamism of the logomark.

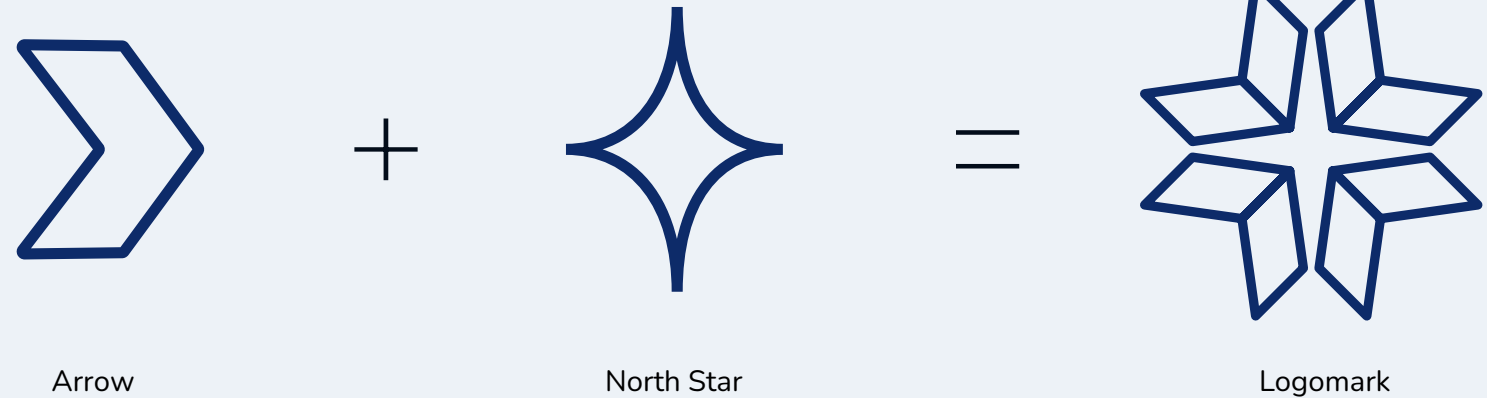

SAI

Wordmark

Primary Logo Lockup

Logomark

The SAI logomark is made up of four arrows that make a north star shape in the negative space.

Wordmark

The wordmark is presented in a modern, easy-to-read typeface that complements the logomark.

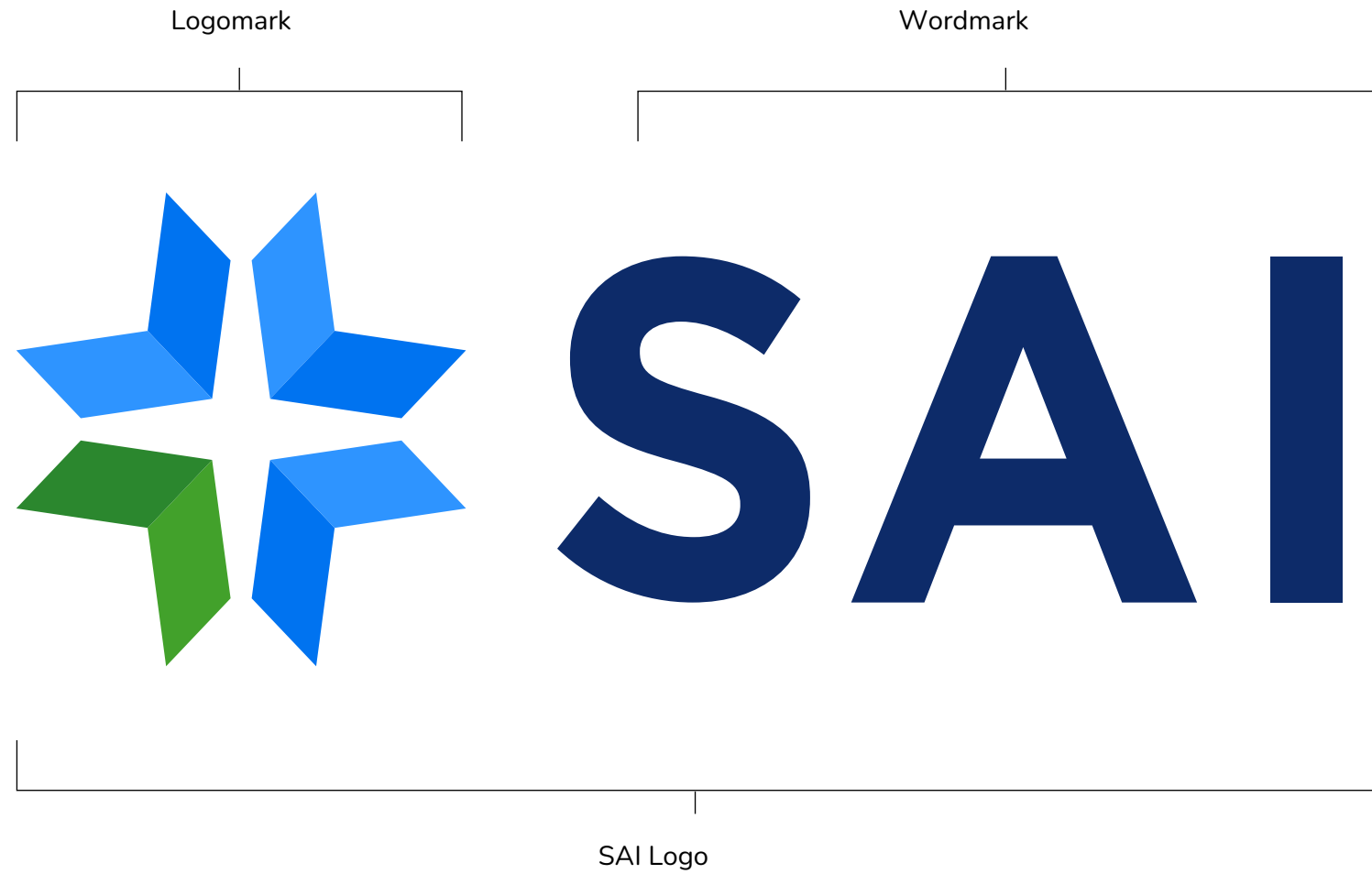

Clear Space + Sizing

Clear Space

Minimum clear space ensures optimum staging and visual impact of the SAI Logo. It is equal to 1/2 the height of the “I” around all sides of the lockup. No other element (type, texture, pattern, etc.) is to appear within the clear space.

Minimum Size

To ensure maximum readability, the SAI logo must always maintain a height of at least 36px for digital / screen applications and 0.5” for printed applications.



SAI LOGO

Logo Use

The logo is the most important visual element in the branding toolkit. It is paramount that the logo be clearly seen and recognized.

Full Color + Single Color Logos

There are multiple color versions of the logo. This page describes how and when they should be utilized.

Only use a single color logo when you cannot use either full color logo.

Use approved logos only

The SAI logo should never be redrawn, recolored, or reinterpreted in any way. The logomark and wordmark have a fixed proportional relationship - never scale or reconfigure the individual elements. Backgrounds should always provide high enough contrast, so the logo is clearly legible.

Full Color Logos

Full Color for light backgrounds



Single Color Logos

Appropriate neutral colors for light backgrounds



Full Color for dark backgrounds



Appropriate neutral colors for dark backgrounds



Logo Misuse

The examples on this page demonstrate some common mistakes to avoid when using the SAI Logo.

Please keep in mind that this list is not exhaustive, and the logo should only be used as outlined in these brand guidelines.



⊗ Do not change the colors of the logo



⊗ Do not reconfigure the logo elements



⊗ Do not change the proportions of the logo elements



⊗ Do not rotate the logo elements



⊗ Do not skew, squish, or stretch the logo



⊗ Do not add effects to the logo



⊗ Do not replace the wordmark with a different typeface



⊗ Do not crop the logo



⊗ Do not place the logo on complex backgrounds

Alternate Lockups

An alternative logo lockup have been created to offer the most flexibility for branded materials. These additional versions should only be used if the primary logo will not work and as outlined in these guidelines. As with the primary logo, clear space and minimum sizing rules apply.

Stacked Logo Lockup

Clear space is equal to the 1/2 the height of the "I" around all sides of the lockup.

The logo must always maintain a height of at least 35 px for digital and screen applications and .5" for printed applications.

Logomark

Clear space is equal to 1/2 the height of the rotated arrow segment around all sides of the lockup.

Use of the isolated logomark is for special cases only (social media profile pictures and fav icons). The minimum size is determined by those instances.

Stacked

Clears Space

Minimum Size

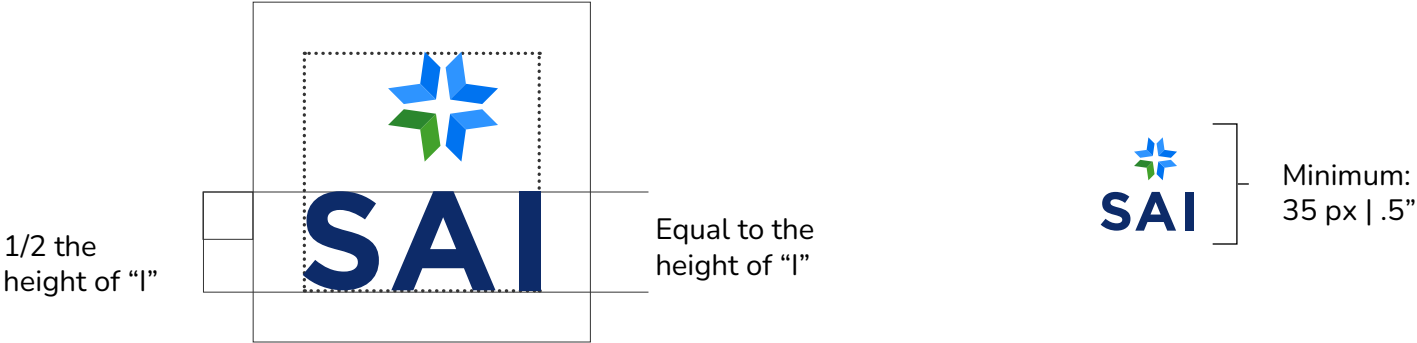

Logomark

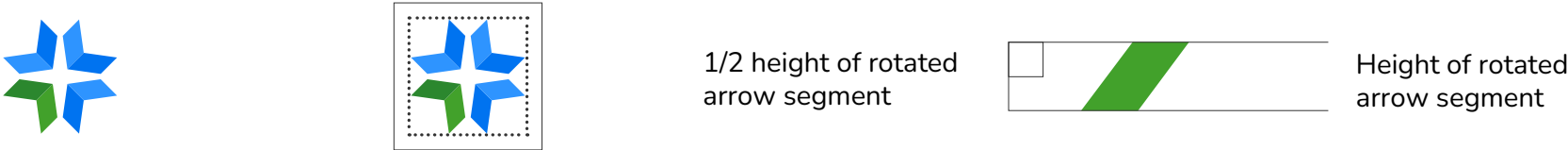

Alternate Lockup Use

As with the primary logo, the alternate logo lockups have full and single colors options for maximum flexibility.

Stacked

Full Color Logos



Light backgrounds



Dark backgrounds

Single Color Logos



Light backgrounds



Dark backgrounds

Logomark

Full Color Logos

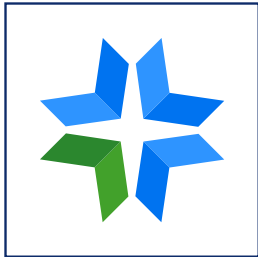

Light backgrounds



Dark backgrounds

Single Color Logos

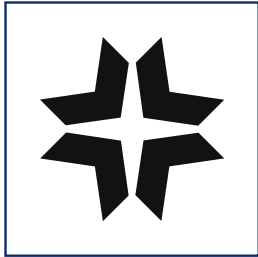

Light backgrounds



Dark backgrounds

SAI LOGO

Division Logos

To accommodate SAI's growing portfolio, the logo was built with a modular approach. Divisional logos are built with northwest facing arrow as the logomark in the corresponding division accent color. The division name is the wordmark. "A Division of SAI" endorsement language is placed underneath the wordmark.

The endorsement should be used when referencing a division on its own or with another division. This will help build awareness and consistency around the greater SAI brand.

By keeping the same logo elements across the division, there is inherent brand continuity and consistency.



**Please note there may be instances where the endorsement is not needed; reach out to CS if you have any questions.*

SAI LOGO

Division Logo Use + Alternates

Multiple logos have been created for each divisional logo, and they follow the same rules as the SAI logo:

1. Use the primary lockup whenever possible
2. Alternate lockups are only to be used when the primary lockup does not fit the space
3. Full color logos should be used wherever possible
4. Single color logos are only to be used when called for (printing, engraving, etc.) or the background is too complex
5. Adhere to the clear space guidelines established underneath each heading the right.
6. Minimum heights for all divisions should be no smaller than 40px | 0.55"
7. Use the correct logo for the background to ensure maximum contrast and legibility

**Please note that these guidelines apply to ALL divisional logos. Fulcrum Research was used as an example.*

Primary

Clear space is 3/4 the height of any letter in large type (e.g. 3/4 height of 'M')



Horizontal

Clear space is the height of any letter in large type (e.g. height of 'M')



SAI LOGO

Logo Lockups

For instances where the SAI name is needed alongside the divisional name or two divisions are needed side by side, lockups have been created.

Division Lockups Use

Lockups are created with the primary brand on the left and secondary on the right, separated by a vertical line (0.75px wide x height of the primary logo). The previous rules for logo use apply to these as well:

1. Full color logos should be used wherever possible
2. Single color logos are only to be used when called for (printing, engraving, etc.) or the background is too complex
3. Adhere to clear space guidelines for the primary logo
4. Adhere to established minimum heights for the primary logo
5. Use the correct logo for the background to ensure maximum contrast and legibility



SAI - Division Lockup



***Co-branding lockups can vary depending on use case.*



Colors

COLOR

Overview

Color is one of the most powerful tools in the SAI brand. Not only does it bring the brand to life but it has the ability to evoke mood, feeling, and meaning where other tools cannot.

The palette contains a varied and rich color scheme but at its core, SAI is a blue brand. Blue represents the company's history and conveys a sense of authority and calmness. The primary blues should be the main colors used throughout communications.

To enhance the look of SAI materials and to better communicate our products and services, bold supporting colors are available for limited use. They should be used as accents and with purpose — to create hierarchy, showcase a CTA, or highlight important information.

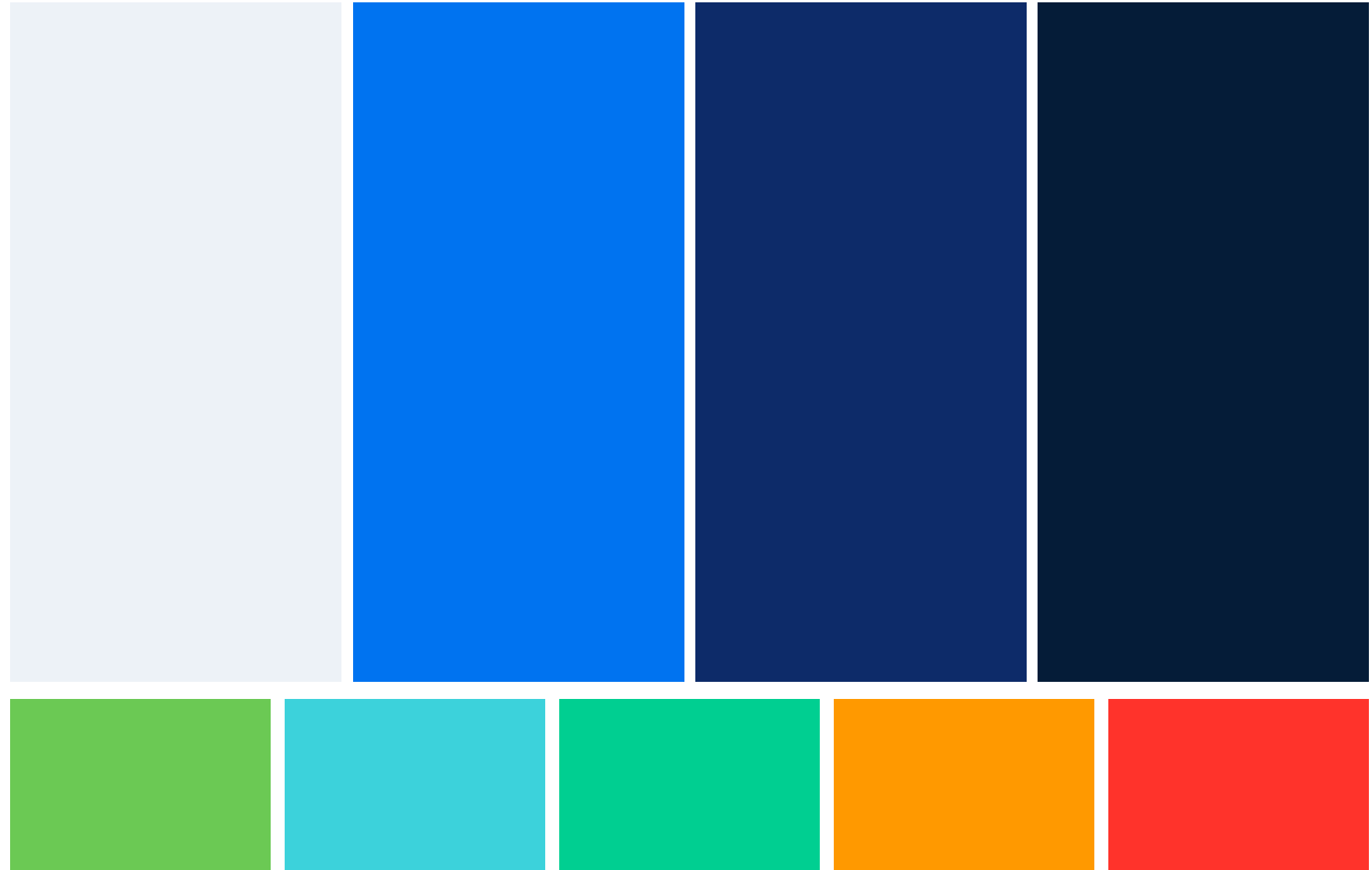

COLOR

Core Colors

There are two groups of colors:

Primary Brand Colors

The primary brand colors are the foundation of the palette. They can be applied without restriction and should account for ~75%+ of the color within a piece.

Accent Colors

Accent colors should be used whenever information needs to stand out, separated, or organized. It should never be the main color and never account for more than ~25% of color within a piece.

While accent colors can be used across all divisions when needed, each division has its own primary accents that take precedence.

Primary Brand Colors

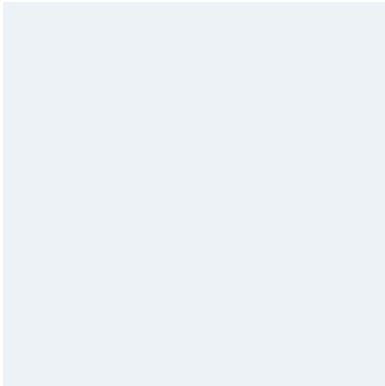

Frost
#EDF2F7



Royal Blue
#0073F0



SAI Blue
#0D2B69



Space Blue
#0051C38

Accent Colors



Apple
#6BC954



Robin's Egg
#3CD2DB



Mint
#00CE92



Tangerine
#FF9900



Coral
#FE322B

**Use appropriate tints / shades of each color for optimal contrast and readability. See pages 28-30.*

COLOR

Gray Palette

To create a well-rounded palette, it's essential to have a collection of neutrals to balance out bold colors or for printing instances where gray scale is required.

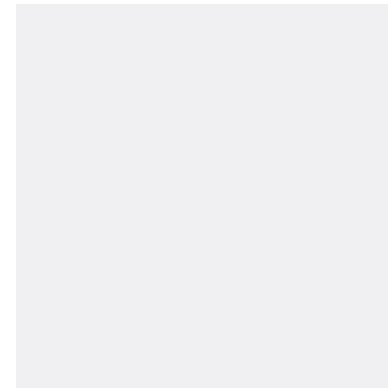

Smoke
#EFF0F2

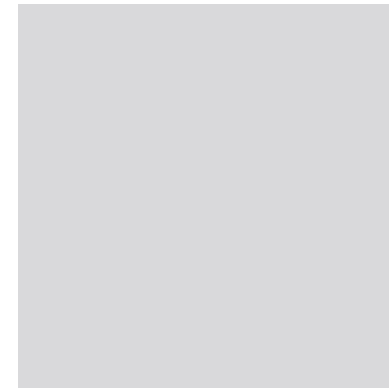

Dust
#D8D9DB



Ash
#979899



Soot
#656566

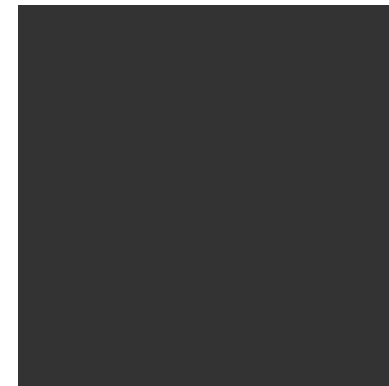

Shadow
#333333



Charcoal
#121314

COLOR

Core Color Usage



Primary Brand Colors: Frost, Royal Blue, SAI Blue, + Space Blue

Primary colors should comprise of 75%+ of the color within a piece.



Accent Colors: Apple, Robin's Egg, Mint, Tangerine, + Coral

The accent color should account for ~25% of color within a piece.



**Use appropriate tints / shades of each color for optimal contrast and readability. See pages 28-30.*

COLOR

Core Color Usage

SAI-Med + Pharmaforce



Primary Brand Colors: Frost, Royal Blue, SAI Blue, + Space Blue

Primary colors should comprise of 75%+ of the color within a piece.



Main Accent Color: Apple

The accent color should account for ~15% of color within a piece.



Additional Accent Colors: Robin's Egg, Mint, Tangerine, + Coral

Additional accent colors should account for less than 10% of color within a piece.



**Use appropriate tints / shades of each color for optimal contrast and readability. See pages 28-30.*

COLOR

Core Color Usage

Fulcrum Research



Primary Brand Colors: Frost, Royal Blue, SAI Blue, + Space Blue

Primary colors should comprise of 75%+ of the color within a piece.



Main Accent Color: Robin's Egg

The accent color should account for ~15% of color within a piece.



Additional Accent Colors: Apple, Mint, Tangerine, and Coral

Additional accent colors should account for less than 10% of color within a piece.



**Use appropriate tints / shades of each color for optimal contrast and readability. See pages 28-30.*

COLOR

Core Color Usage

IDEA Pharma



Primary Brand Colors: Frost, Royal Blue, SAI Blue, + Space Blue

Primary colors should comprise of 75%+ of the color within a piece.



Main Accent Color: Coral

The accent color should account for ~15% of color within a piece.



Additional Accent Colors: Apple, Mint, Tangerine, and Robin's Egg

Additional accent colors should account for less than 10% of color within a piece.



**Use appropriate tints / shades of each color for optimal contrast and readability. See pages 28-30.*

COLOR

Tints + Shades

Color harmony goes beyond the core shades of a palette and extends into a series of tints and shades. Having a full range of each color allows the greatest flexibility and balance.

Tint - The mixture of a core color with white making it lighter. The more white you add, the lighter the new color becomes.

Shade - The mixture of a core color with black making it darker. The more black you add, the darker the new color becomes.

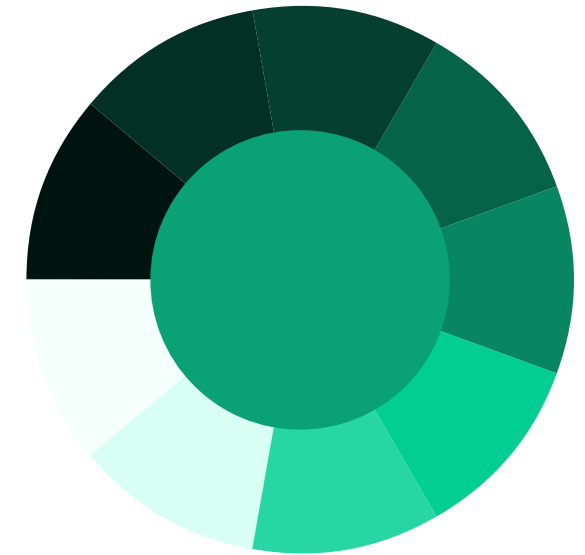
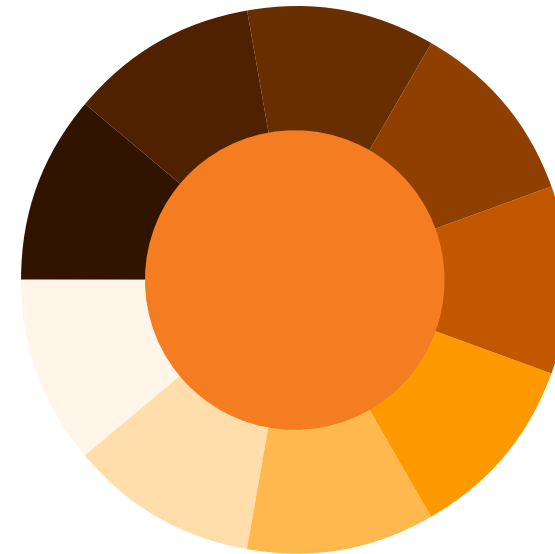
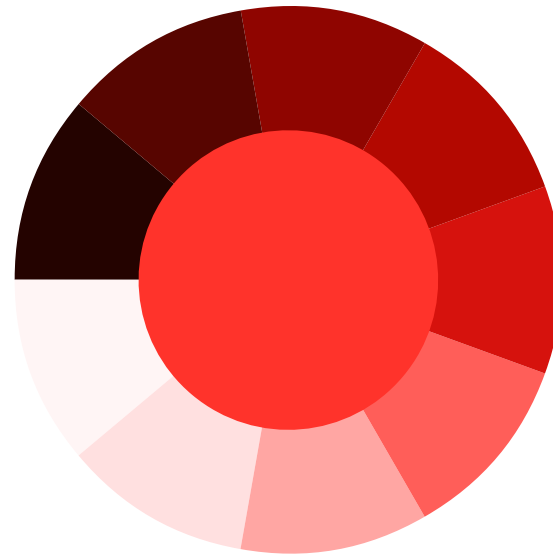
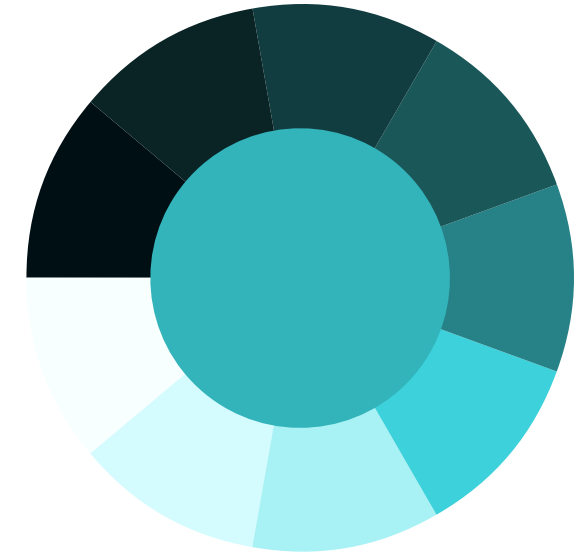
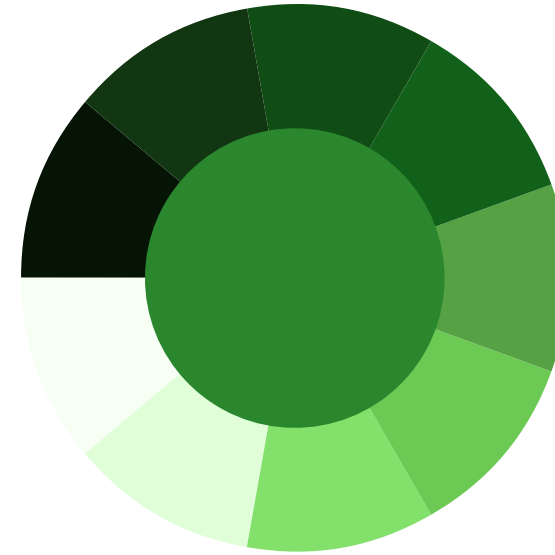
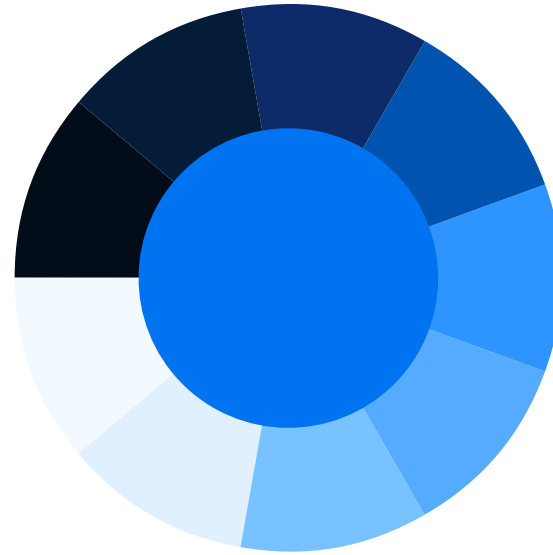

COLOR

Contrast

Color only works in our favor if the contrast is great enough between the content and the background. If the contrast is too low, the readability will suffer.

To ensure materials are as readable as possible, use dark text, icons, etc. on light backgrounds and light text, icons, etc. on dark backgrounds.

Dark Backgrounds

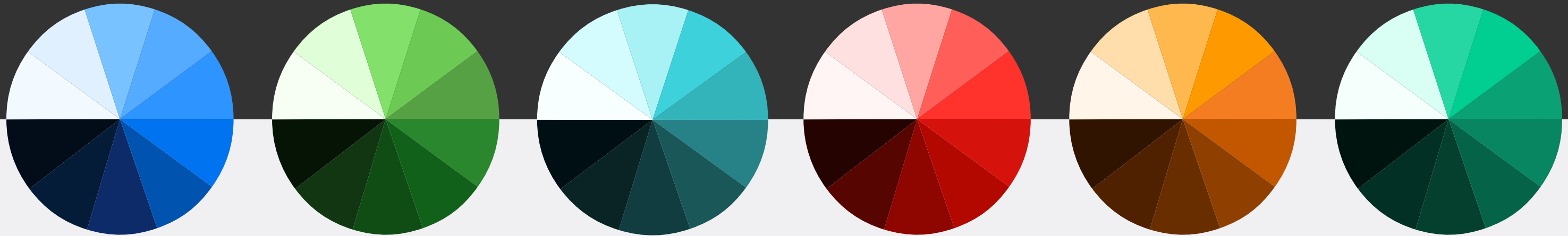

Light Backgrounds

COLOR

Color Use + Accessibility

Colors

Each of the core colors have tints and shades that range from very pale / almost white to very deep / almost black.

Color Use

Each color range has specific uses. Follow the correct use for each color.

Accessibility (For Web Only)

Even the most carefully crafted communications will fail to make an impact if they cannot be seen properly. There needs to be adequate contrast between content and the background to meet on-screen ADA compliance. Always adhere to these guidelines to ensure your digital communication is legible for all viewers.

COLORS

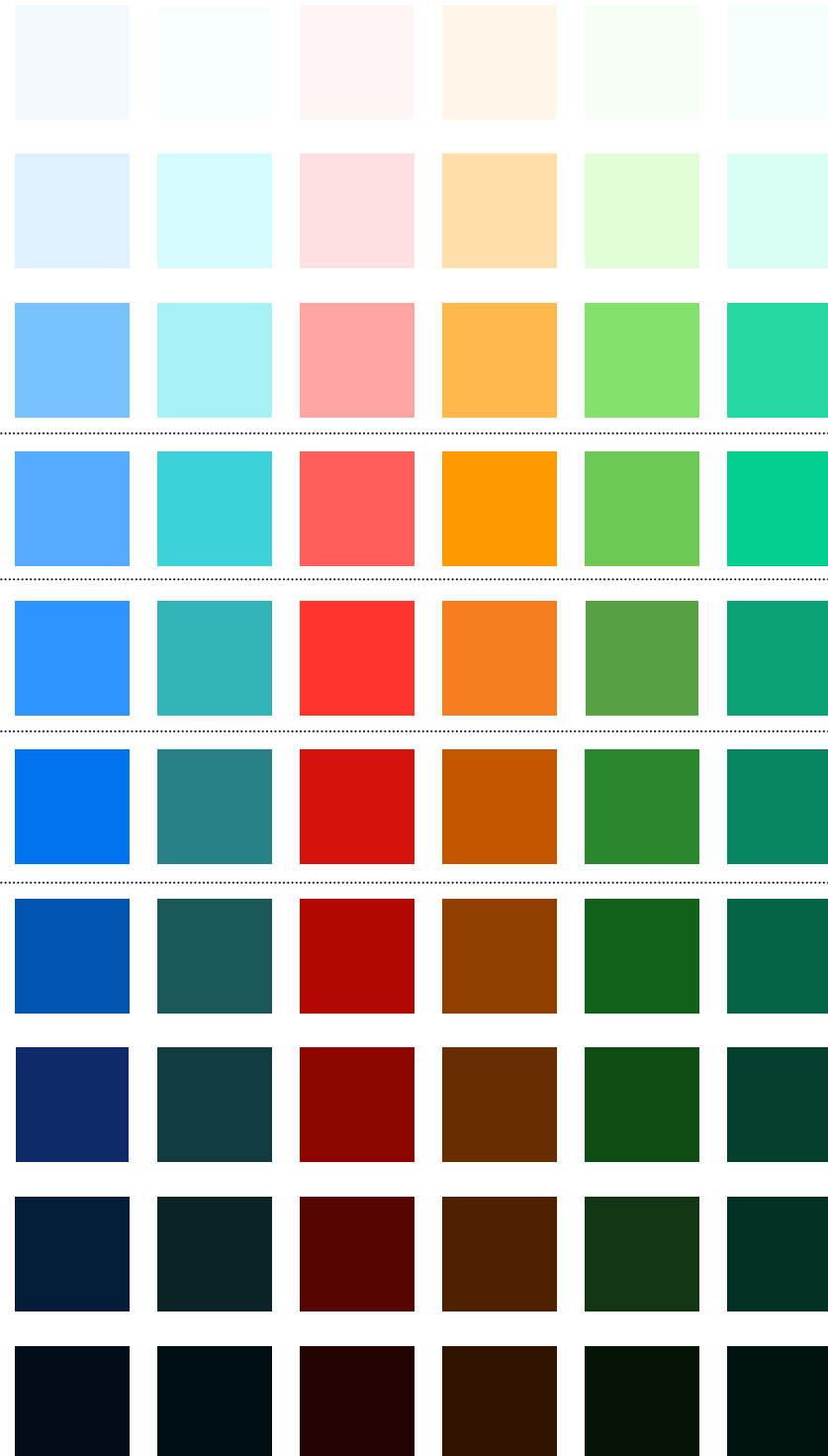

USE

Light backgrounds, light gradients, and alternative text color to pure white

Light gradients

Content on dark backgrounds

Content on dark backgrounds

Content on light and dark backgrounds

Content on light backgrounds

Content on light backgrounds

Dark backgrounds and gradients

Dark gradients

Alternative text color to pure black

WEB ACCESSIBILITY

AAA compliant on dark colors

AA compliant on dark colors

AA compliant on light and dark colors



























































AA compliant on light colors

AAA compliant on light colors

COLOR

Color Codes

The hex color codes for the entire color palette.

	Frost #EDF2F7		Ice #F2F9FF		Green Mist #F7FFF5		Mist #F7FFFF		Mint Cream #F5FFFC		Blush #FFF5F5		Almond #FFF5E8
			Powder #E0EFFF		Honeydew #E0FFD9		Pale Cyan #D4FCFF		Seafoam #D9FFF4		Misty Rose #FFE0E0		Peaches 'n Cream #FFDEAB
			Sky #78C2FF		Lime #83E06C		Aqua #A9F1F5		Mint #2AE8B2		Rose #FFA6A3		Golden Rod #FFB84D
			Cornflower #54AAFF		Apple #6CC955		Robin's Egg #3CD2DB		Caribbean #25CC9C		Melon #FF5E59		Tangerine #FF9900
	Smoke #EFF0F2		Azure #2E93FF		Grasshopper #43A12B		Bondi Blue #33B2BA		Jungle #0AA176		Coral #FF332B		Orange #F57D21
	Dust #D8D9DB		Royal Blue #0073F0		Emerald #2B872E		Cerulean #258287		Sea Green #088561		Red #D6120D		Burnt Orange #C25700
	Ash #979899		Sapphire #0053B0		Forest #136119		Blue Lagoon #1A5759		Castleton #066347		Scarlett #B20800		Eclipse #8F4000
	Soot #656566		SAI Blue #0D2B68		Hunter #0F4D14		Sherpa Blue #123C40		Viridian #04402E		Maroon #8F0500		Brown #692E00
	Charcoal #333333		Space #051D38		Moss #113612		Park After Dark #0A2426		Dark Green #033023		Deep Maroon #570500		Fall Forest #4F2100
	Shadow #121314		Midnight #020D1A		Black Forest #061406		Deep Ocean #001014		Deep Jungle #01140F		Deep Red #240300		Deep Fall Forest #301400

COLOR

Gradients

Gradients help create depth in communications and designs. They can be used as backgrounds, overlays, or graphic element fills.

Gradients can be formulated using the HEX color codes on page 31. They can be horizontal, vertical, or diagonal but not radial. They should follow the color usage rules on pages 24-27.

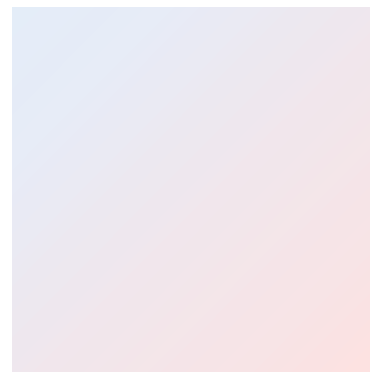



Typography

TYPOGRAPHY

Our Typefaces

In visual materials, typefaces help convey a brand's character, tone of voice, and message. Our SAI brand typefaces have been curated to deliver optimum readability while accentuating our personality - approachable, knowledgeable, and trustworthy.

Our preferred typefaces are Montserrat and Nunito. If either of these fonts are unavailable (e.g. in PowerPoint), please use Calibri as a replacement.

Moreover, these are Google fonts making them easily accessible for everyone.

Montserrat

Nunito

Calibri

Calibri should only be used for PowerPoint and when Montserrat and Nunito are unavailable.

TYPOGRAPHY

Montserrat

Montserrat is our typeface for titles, headings, and sub-headings. It is modern, clean, and legible.

This variable font family features a tall x-height aiding in the readability of mixed-case and lowercase text, making it an ideal typeface for legibility and flexibility in today's digital world.

We have carefully selected the type weights that should be used and created specific use cases for each. By following the guidelines listed on the following pages, you will ensure Montserrat remains legible and impactful across our entire design system.

abcdefghijklm

nopqrstuvwxyz

ABCDEFGHIJKLM

NOPQRSTUVWXYZ

0123456789

Extra Light

Light

SemiBold

TYPOGRAPHY

Nunito

Nunito is our typeface for body copy. It is a highly legible sans serif that complements Montserrat nicely.

We have carefully selected the weights that should be used and created specific use cases for each. By following the guidelines listed on the following pages, you will ensure Nunito is used correctly to maintain readability and continuity across communications.

abcdefghijklm

nopqrstuvwxyz

ABCDEFGHIJKLM

NOPQRSTUVWXYZ

0123456789

Regular

Italic

Bold

TYPOGRAPHY

Sizing Headlines

Our typeface for all headlines and titles is Montserrat. The easy-to-read characters display well across different sizes and lend a clean, professional look to our communications.

The weight of the typeface will vary depending on the size of the headline.

Large Headlines

Headlines that are 64pt and larger use Montserrat Extra Light.

Small - Regular Headlines

Headlines that are 16pt - 63pt use Montserrat Light.

Very Small Headlines

Headlines smaller than 16pt use Montserrat SemiBold.

Sub-Headlines

Sub-headlines can be in either Montserrat Light or SemiBold depending on the size and layout of content. Sub-headlines within body copy must be Montserrat SemiBold in order to stand out.

130pt
Large headline
Montserrat Extra Light

Headline

100pt
Large headline
Montserrat Extra Light

Headline

72pt
Large headline
Montserrat Extra Light

Headline

48pt
Headline
Montserrat Light

Headline

24pt
Small headline /
sub-headline
Montserrat Light

Headline / Sub-Headline

15pt
Very small headline /
Body sub-headline
Montserrat SemiBold

Headline / Sub-Headline

TYPOGRAPHY

Type Styling

Correctly styling the typography will ensure consistency across communications, strengthen brand recognition, and maintain SAI's professional reputation.

Alignment

Type should always be left-aligned except in very special cases where center alignment is acceptable. Type should never be right-aligned.

Case

Type should be sentence case or title case based on content. Type may be all caps when used for a short category title — 3 words or less.

Orientation

Type should always be horizontal. Do not rotate in any direction.

Bullets

Bullets need adequate spacing between each item. Space After should be set to at least 6px. The actual bullet points should be in line with the copy with the indent set to 15px.

Headline 1

Montserrat Extra Light
Optical Kerning
Set to 0 Tracking
110% Leading

Headline 2

Montserrat Light
Optical Kerning
Set to 0 Tracking
110% Leading

Headline 3

Montserrat Light
Optical Kerning
Set to 0 Tracking
110% Leading

Body Copy + Bullets

Am quae seq uaspeliquunt pro officiat
nos aut occat. Dolo officii tem earumquo
optas dolorum volo quia coreperibus.

- Amendit volo verum nis
- Ugit am estrum estrum escipit

Nunito Regular
Optical Kerning
Set to 0 Tracking
120% Leading

Captions

Nunito Italic
Metric Kerning
Set to 0 Tracking
120% Leading

Sub-Headline 1

Montserrat Light
Optical Kerning
Set to 0 Tracking
125% Leading

Sub-Headline 2

Montserrat SemiBold
Optical Kerning
Set to 0 Tracking
125% Leading

Quotes

Nunito Italic
Metric Kerning
Set to 0 Tracking
150% Leading

— Attributions

Nunito Bold
Optical Kerning
Set to 0 Tracking
125% Leading

TYPOGRAPHY

Type Hierarchy

Type hierarchy is the organization of typographical elements in a design to guide the viewer's eye through the content in order of importance. It is crucial because it helps users: avoid being overwhelmed, take in the information, quickly find relevant information, and separate relevant information from irrelevant content.

Following these guidelines will ensure that our communications boast a polished and cohesive look that reflects SAI's standing as a global healthcare leader.

Montserrat

Montserrat Extra Light and Light are our fonts for headlines and sub-headlines. In specific use cases, it is acceptable to use Montserrat SemiBold for headlines and sub-headlines: when the size of headline is small or when the sub-headline is within the body of a piece. See page 34 for specific sizing requirements.

Nunito

Nunito regular is our font for body copy. Nunito bold may be used to emphasis words or phrases within body copy, and it should be used for attributions. Nunito italic is our font for quotes.

Montserrat SemiBold — CATEGOREY

Montserrat Extra Light — Lorem Ipsum

Montserrat Light — Ro tem audandias est accullatur sitatquas que occulle Nam, tem voluptat earupicipsae nobitat

Nunito Regular — Lorem ipsum dolor sit amet, consectetur adipiscing elit, sed diam nonummy nibh euismod tincidunt ut laoreet dolore magna aliquam erat volutpat. Ut wisi enim ad minim veniam, quis nostrud exerci tation ullamcorper suscipit lobortis

Montserrat SemiBold — Lorem Ipsum

Lorem ipsum dolor sit amet, consectetur adipiscing elit, sed diam nonummy nibh euismod tincidunt ut laoreet dolore magna aliquam erat volutpat.

Ut wisi enim ad minim veniam, quis nostrud exerci tation ullamcorper suscipit lobortis

Lorem Ipsum

Lorem ipsum dolor sit amet, consectetur adipiscing elit, sed diam nonummy nibh euismod tincidunt ut laoreet dolore magna aliquam erat volutpat.

- Amendit volo verum nis a quam lantia vid quatur, ipid moluptam, sant ut optus.
- Ugit am estrum estrum escipit desecat iiscim auda nit aut ilitatem ipicidunto voluptae none quae nectatatur
- Tempostia nessi corionsequia digentio officip sanimi, que es ea iumquae riatur.

“Lorem ipsum dolor sit amet, consectetur adipiscing elit, sed diam nonummy nibh euismod tincidunt ut laoreet dolore magna aliquam erat volutpat.”

— Chelsea Doe

“Lorem ipsum dolor sit amet, consectetur adipiscing elit, sed diam nonummy nibh euismod tincidunt ut laoreet dolore magna aliquam erat volutpat.”

— John Middlebrook

Nunito Italic



Lorem ipsum dolor sit amet



Lorem ipsum dolor sit amet



Lorem ipsum dolor sit amet

Nunito Regular

Nunito Regular — sai-med.com | info@sai-med.com



Photography

PHOTOGRAPHY

Overview

Photography plays a key role in bringing the SAI brand to life. We have three categories of photography:

Authentic + Candid

By depicting authentic and candid human moments, our photographic style carries an air of approachability and recognizability that draws people in.

Photographs using people should be representative of various races, ages, genders, and ethnicities.

Industry-Specific

Our industry-specific imagery of organisms, cell structures, additional biologic subjects, as well as graphs and data, tie into our mission to move healthcare forward while providing context to our clients' work.

Scenic Accents

Our expansive shots of scenery - global, urban, natural - illustrate the breadth of our brand's reach and highlight the many corners of the globe that have been touched by our mission. Additionally, scenic photographs allow us to add color, texture, and visual depth to our communications.

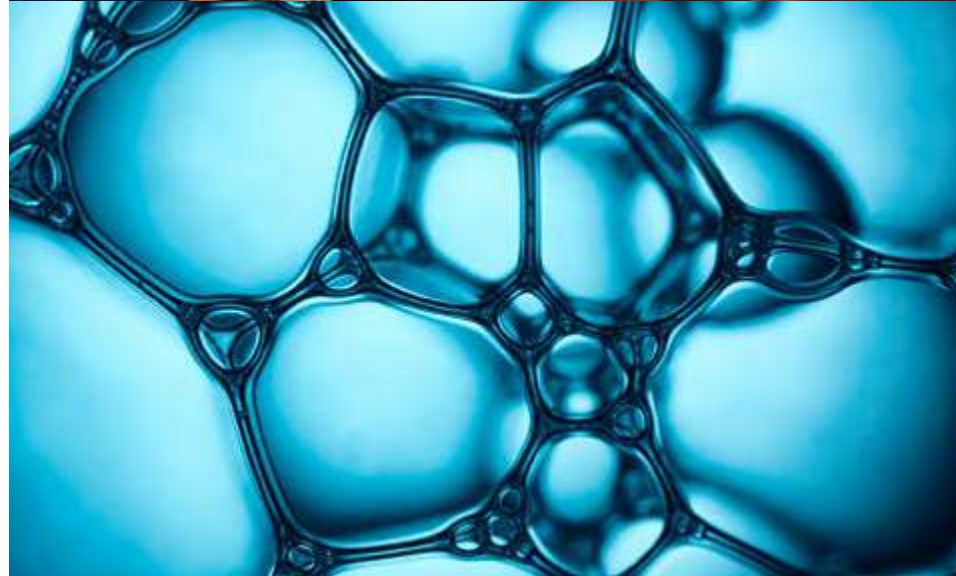

PHOTOGRAPHY

Authentic + Candid

What continually drives SAI is knowing how impactful our work is in the healthcare and pharmaceutical industries. And more importantly, how our work has the potential to change the lives of people around the world.

With this in mind, the Authentic + Candid category celebrates genuine human connection and forward-facing optimism. This photographic style employs a shallow depth-of-field and a composition that allows authentic, candid, and aspirational moments to shine through and be the focal point.

- Person or people caught in a moment - never posed or stiff
- Authentic, candid, optimistic, aspirational
- Soft depth of field and framing the composition to focus attention on the moment
- Natural emotions - never forced, no fake smiling or laughing
- Photographs should depict a full range of positive emotions
- Photographs using people should be representative of various races, ages, genders, and ethnicities



PHOTOGRAPHY

Industry-Specific

At SAI, we work hard to deliver transformative insights to our clients. Our Industry-Specific category highlights the important work both we and our clients do every day from critical data analysis to pharmaceutical and biologic research. These striking images can be used as a backdrop for which we can create impactful communications telling engaging brand stories.

- Engaging images showcasing data and / or analysis
- Imagery reflecting the therapeutic areas SAI supports - oncology, immunology, rare diseases, vaccines, etc.
- Close-up shots bring a visual depth to our photography that help legitimize the brand
- Shots taken at a distance help provide context to the work and aid in visual storytelling
- All imagery should exude a sense of science, research, data / analysis, biologics, or healthcare

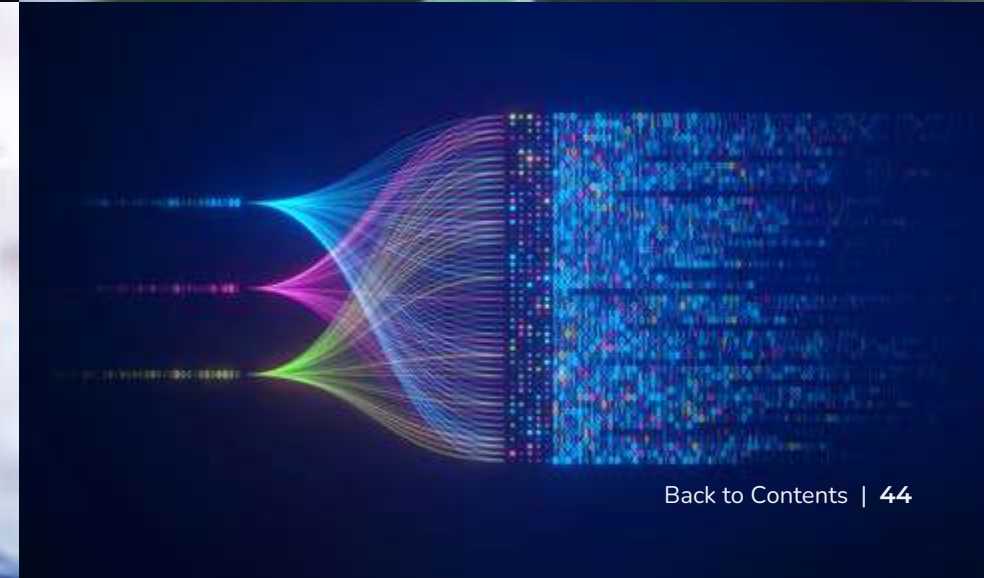
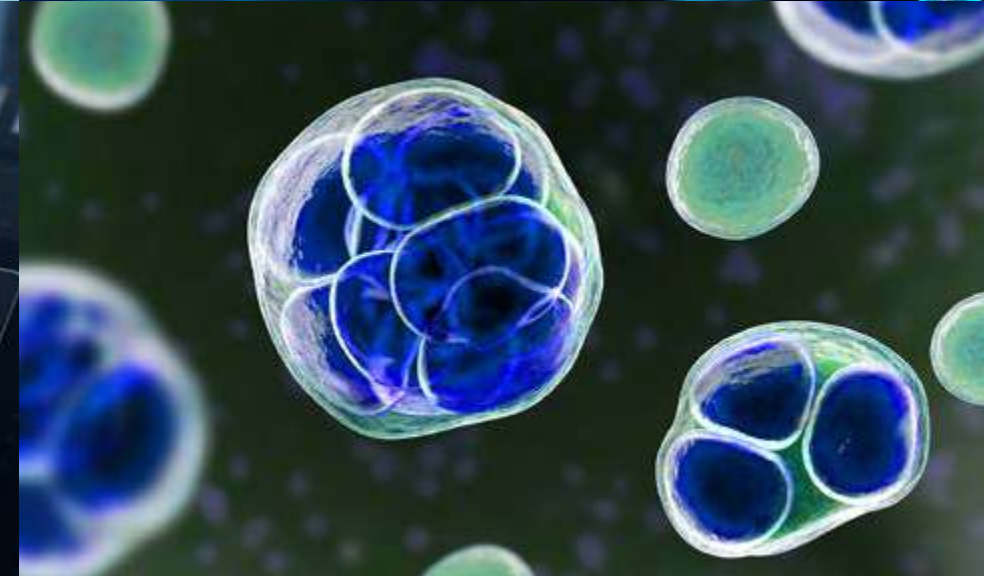

PHOTOGRAPHY

Scenic Accents

As a global leader, the SAI brand has the power to influence the world in ways both small and large. Our Scenic Accents category displays the expansive landscapes we inhabit in our day to day work. From urban cityscapes to sprawling forests and fields and all the way to outer space, we are confronted with the juxtaposition of the natural and industrial worlds. By celebrating both the beauty of our surroundings and the power of human innovation, these images reflect the spectrum of impact and work found within SAI — human vs technology, micro vs macro, and past vs future.

Scenic Accent photography should be used as the name implies - for accents only. The addition of these images should provide visual depth, color, and texture to our communications to highlight the many facets of SAI and our work.

- A variety of images that demonstrate SAI's expansiveness and global reach
- Landscapes whether urban, rural, or astronomical should feel dynamic and alive — never stagnant or sterile
- Shots should range from daytime to nighttime while remaining well-lit to accent not just our brand but the people and places it affects



PHOTOGRAPHY

Scenic Accents in Action

Scenic Accent photography should be used as the name implies - for accents only. They should never be used for hero images or as the main focus. The addition of these images should provide visual depth, color, and texture to our communications to highlight the many facets of SAI and our work.

- A background image with a color overlay
- Cropped image to add color, texture, or depth



Gradient overlay applied on top of image

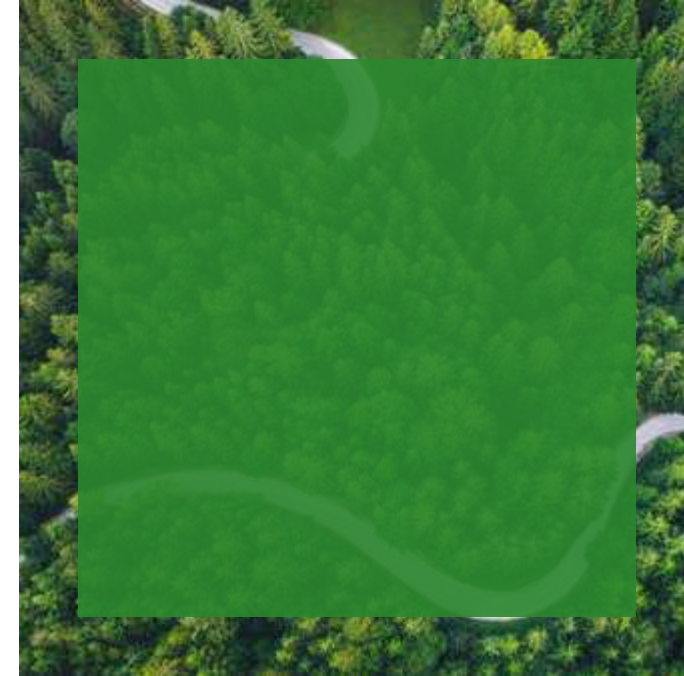

Color overlay box applied on top of image



Accent image on the side of a communication

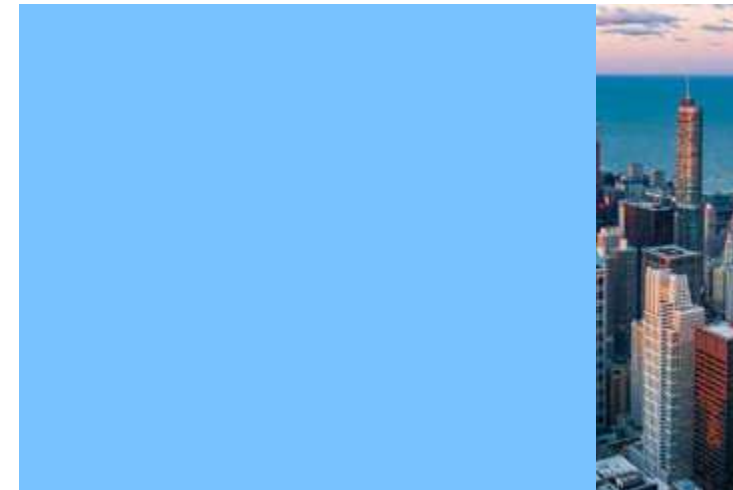

PHOTOGRAPHY

Photo Misuse

The examples on this page demonstrate some common photography mistakes to avoid. This list is not exhaustive.

Photography should only be used when it enhances the story or context of a communication. Using photography for photography's sake is not in line with the SAI brand.



❌ Do not use posed or staged images



❌ Do not use inauthentic images or subjects looking directly at the camera



❌ Do not use overlays on top of photography



❌ Do not use highly manipulated images



❌ Do not use moody images or those overly negative



❌ Do not use clichéd images



❌ Do not use overly complicated images with no clear focal point



❌ Do not use images with irrelevant subject matter



Iconography

ICONOGRAPHY

Icons

Iconography is a fundamental part of any visual system. Icons help us to quickly navigate, better understand a concept, and they are independent of language.

SAI's iconography reflects our brand's character through a simple and modern approach to ensure clarity in our communications.

Iconography Style and Usage

- Consistent and uniform thin-weight lines
- Uniform in size
- One color per icon
- Recognizable

Icon Misuse

- Photo replacements (icons are not complex enough to replace a photograph)
- Mixed line weights
- Multiple colors
- Overcomplicated
- Unrecognizable
- Filled in

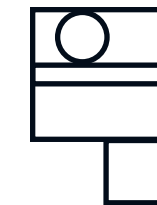
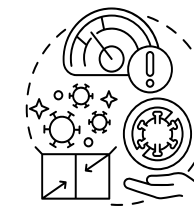
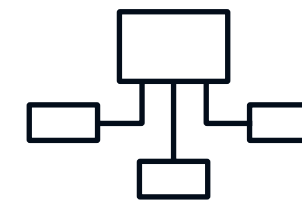
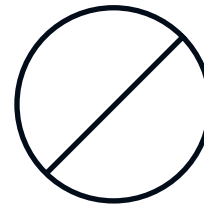
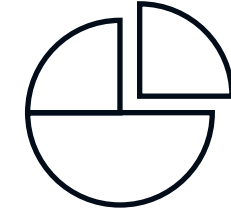
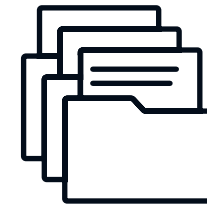
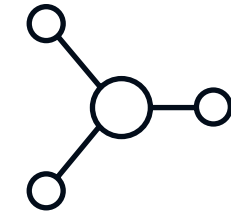
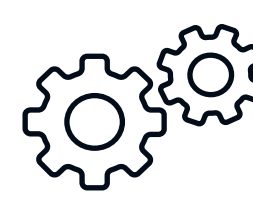

 Do not fill in icons

 Do not use mixed line weight icons

 Do not use complicated icons

 Do not use unrecognizable icons



Graphic Elements

GRAPHIC ELEMENTS

Overview

The SAI logo is built from four arrows that create a north star in the negative space. Utilizing these simple yet bold shapes as graphic elements not only create brand recognition but allow us to build truly unique designs separating SAI from the competition.

Moreover, the arrows and star represent SAI's purpose to drive progress forward, guide our clients through challenges, and position us as a trusted partner illuminating the path to growth. Including graphic elements constructed from the foundational building blocks of the SAI brand strengthens our visual identity and our communications.

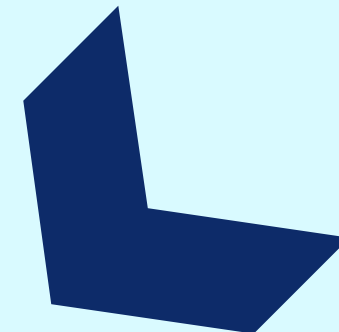
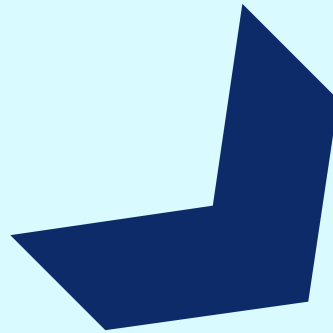
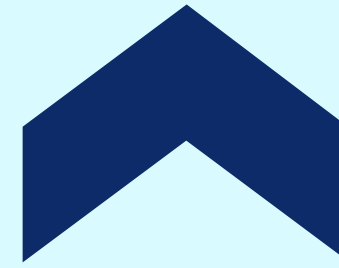

GRAPHIC ELEMENTS

Graphic Elements

Graphic elements can be used in a variety of ways to create unique designs, highlight information, and strengthen brand identity:

- In conjunction with photographs
- Visual interest and depth
- Filled in with a solid color or gradient or as an outline
- Background elements

Logo Elements

Primary

The primary graphic elements represent upward and forward movement in the arrow shapes and the star serves as a guiding light. These shapes denote positivity, growth, and progress.

Secondary

The secondary graphic elements are the remaining orientations of the logomark arrow. They are to be used minimally since they can carry connotations of regression, backwards movement, and negativity. However, since various arrow directions can represent agility and adaptability, they can still be used.

Other Elements

Additional approved graphic elements include expanded arrow shapes, path lines, and circles.

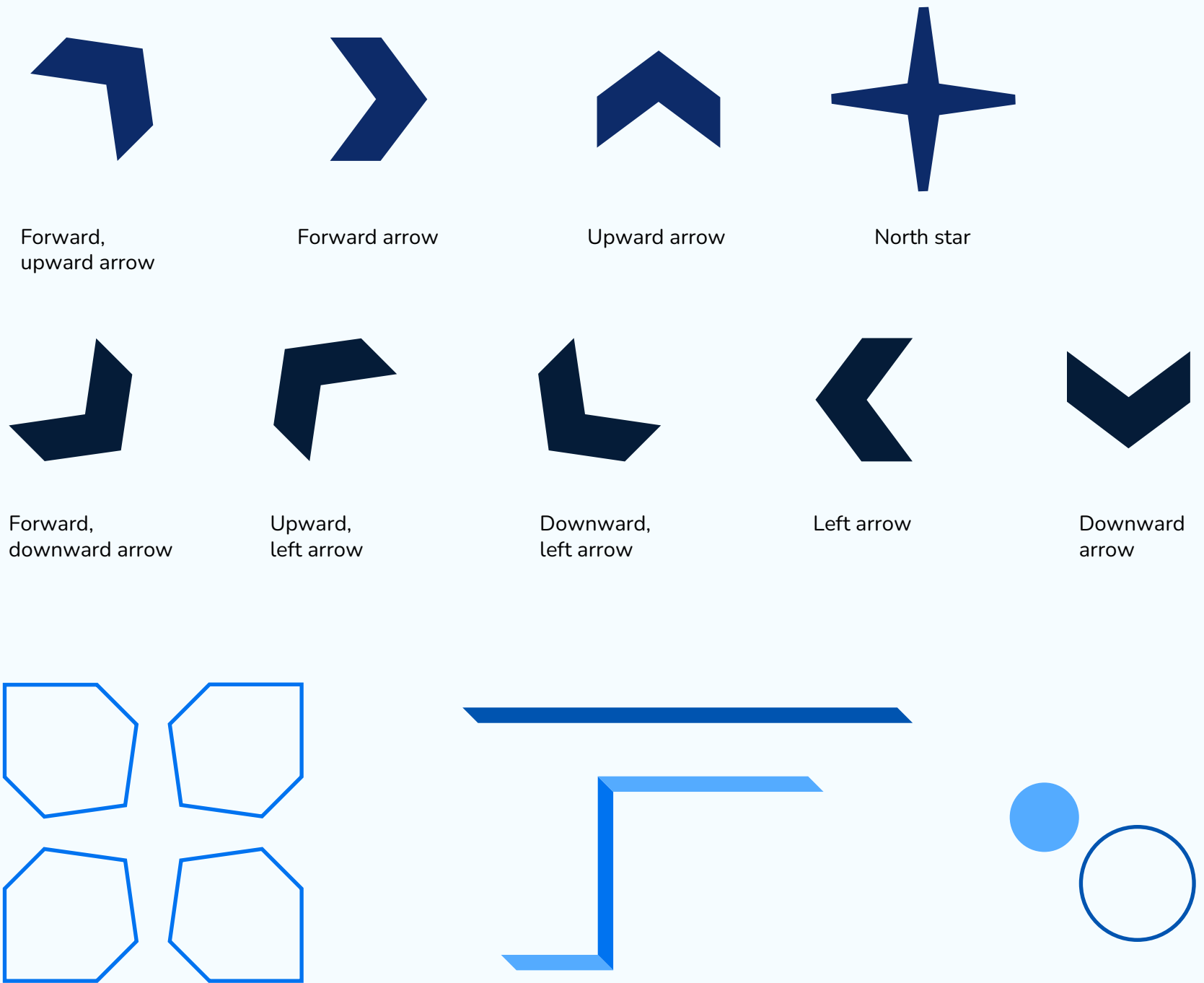

GRAPHIC ELEMENTS

Graphic Vessels

Using specific angles from the two forward arrows, vessel shapes can be created and used for copy and / or images. Vessels can have one angled side or parallel angled sides so long as the angles match. They can be rotated 90° and reflected over the x- and y- axes.

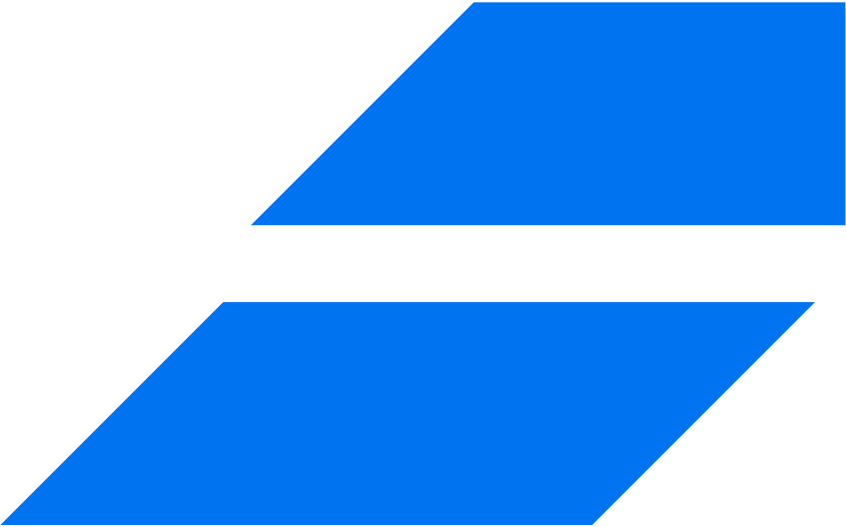
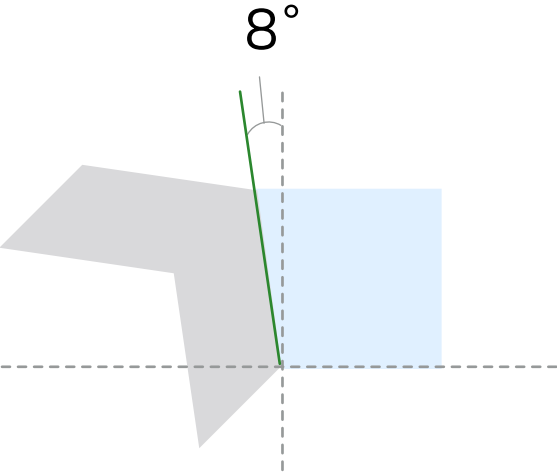
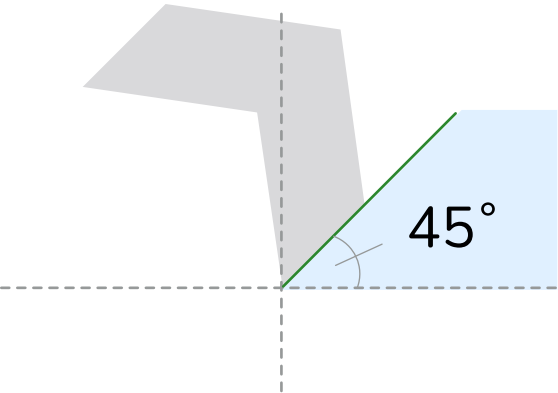

In Action

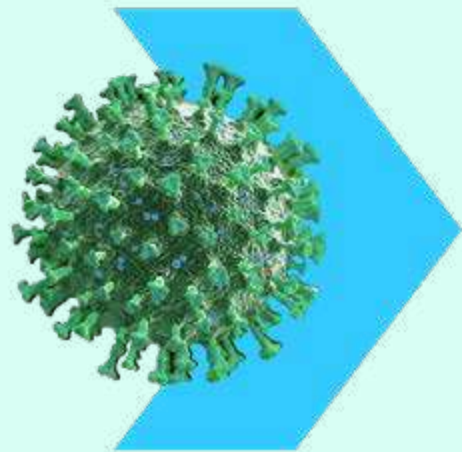
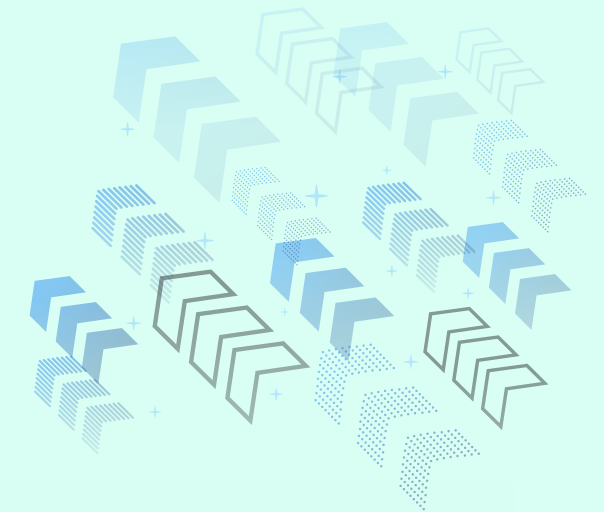



Patterns

PATTERNS

Overview

Our expressive patterns showcase the dynamic and insightful nature of our work communicating not only the precision of what SAI does but also the broader strategic direction we bring to every project. We deliver cutting-edge intelligence with a focus on navigating challenges and capitalizing on opportunities in the ever-evolving competitive landscapes.

All of the patterns utilize two simple shapes derived from the logomark. Arrows represent forward momentum and strategic direction, progress, precision, and insights while stars serve as a symbol of clarity, excellence, moments of discovery, and breakthroughs.

These patterns were created to be flexible for use across many design applications to add a touch of boldness to our communications. When applied to layouts, these striking patterns add a layer of impact and visual depth.

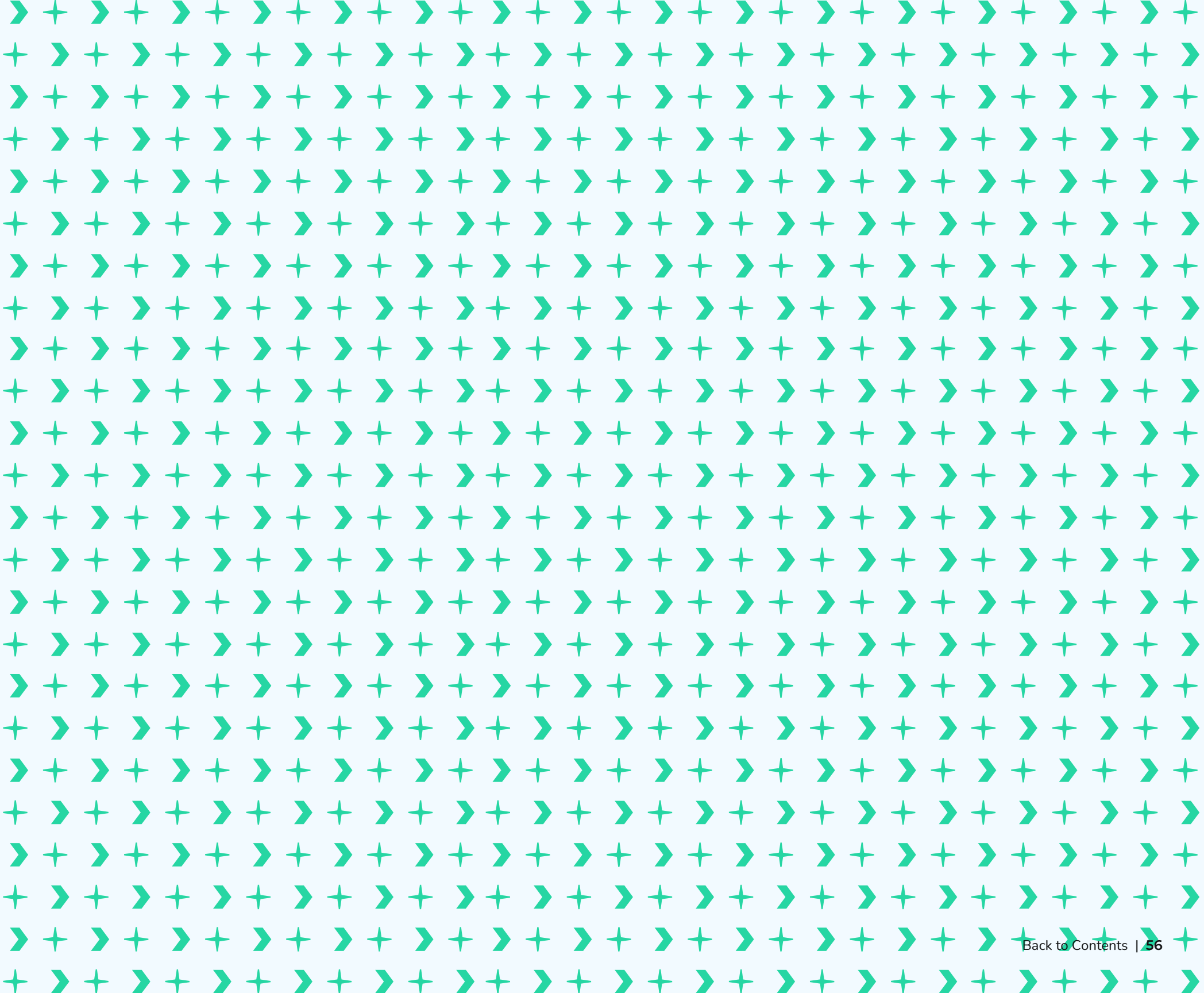

PATTERNS

Patterns / Textures

There are six patterns / textures, none of which are to be combined.

They are to be used as accents only. While they should be noticeable, they should never be the main focus of a communication.

Colors can be changed and adjusted to fit each piece.

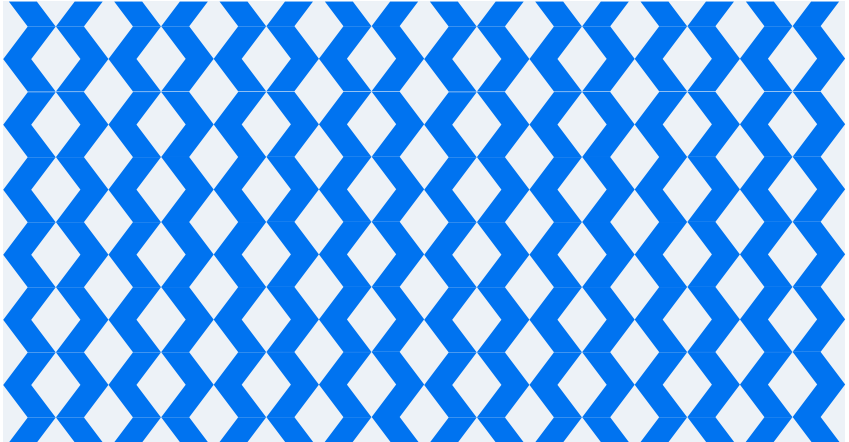
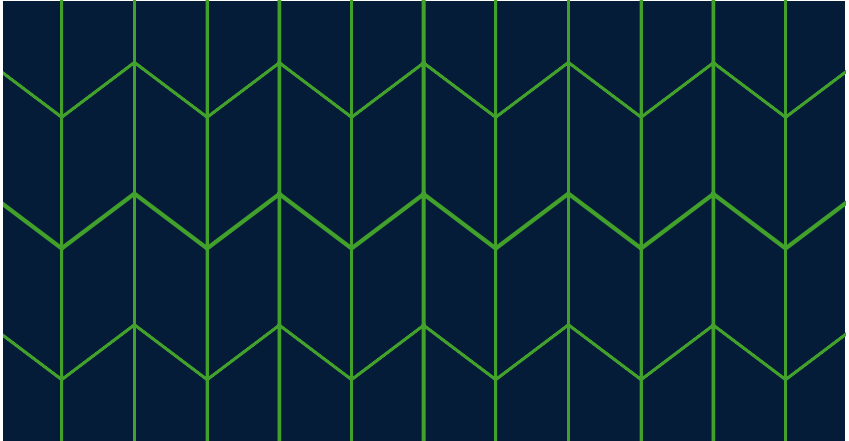

PATTERNS

In Action

Small Scale

Use on photography or solid colors / gradients for a subtle approach that does not interfere with messaging.

Medium Scale

Use on simple photography or solid colors / gradients to garner more visual interest while not detracting from the other elements.

Large Scale

For use only in simple compositions featuring a solid color / gradient background allowing the pattern to add a sense of movement and dimensionality to the piece.





Illustrations

ILLUSTRATIONS

Overview

SAI's custom, hand-drawn illustrations play a vital role in shaping our unique brand identity. These illustrations are more than just visual accents—they serve as a distinctive storytelling tool that enhances clarity, engagement, and brand recognition across all materials.

The bespoke nature of these illustrations conveys authenticity, creativity, and a human touch. They help simplify complex concepts, making them more accessible and visually appealing. Their hand-drawn style adds warmth and personality, balancing data-driven content with approachable visuals.

Our illustrations seamlessly align with SAI's overall visual language by complementing our color palette, typography, and tone of voice. Used consistently, they strengthen brand recognition and create a cohesive, memorable experience for clients and stakeholders.

Illustrations should be employed in key reports, presentations, and marketing collateral to highlight critical insights, showcase processes, or visualize concepts. Use them thoughtfully to maintain visual hierarchy, ensuring they enhance rather than distract from the core message.

**Please reach out to Becca H if you need any illustrations or have illustration requests.*





Grid + Layouts

Grid System Overview

The grid system allows us to make polished, on-brand layouts quickly and consistently. There are four main steps in creating a layout:

1. Build grid
2. Size logo
3. Adjust the grid
4. Lay out elements

The following pages will go over each step in more detail.

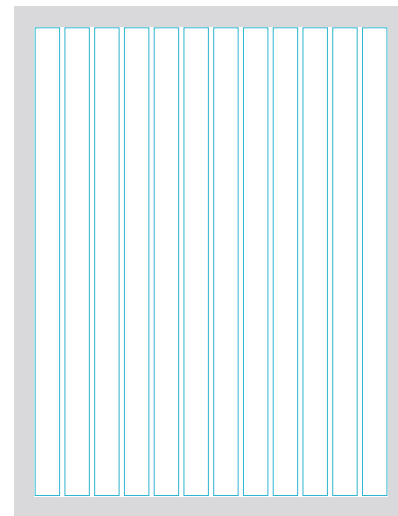

1. Create your grid

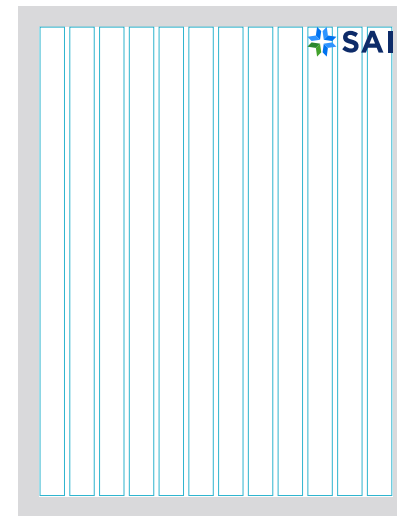

2. Using the grid, size your logo

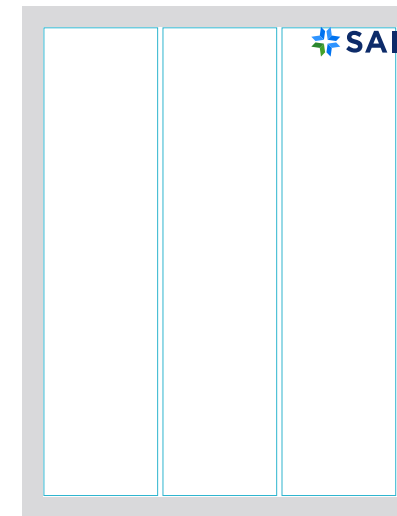

3. Adjust the grid based on your content

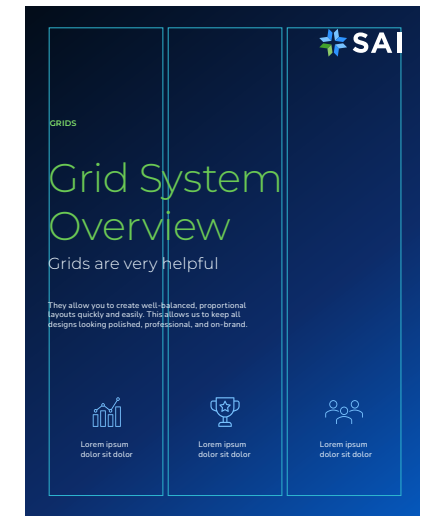

4. Use your finished grid to lay out your elements

Layout Terms

A grid is the foundation of a layout. They help ensure consistency across our communication designs while allowing flexibility for creative freedom.

When drawing a grid, you need three basic structural components: margins, columns, and gutters.

Margins

The area around a layout that frames the design. Content may not be placed in the margins.

Columns

Vertical divisions that contain the content of a design. Each column is the same width and separated by gutters.

Gutters

The space in-between the columns. Gutters improve readability. Each gutter is the same width within a grid.

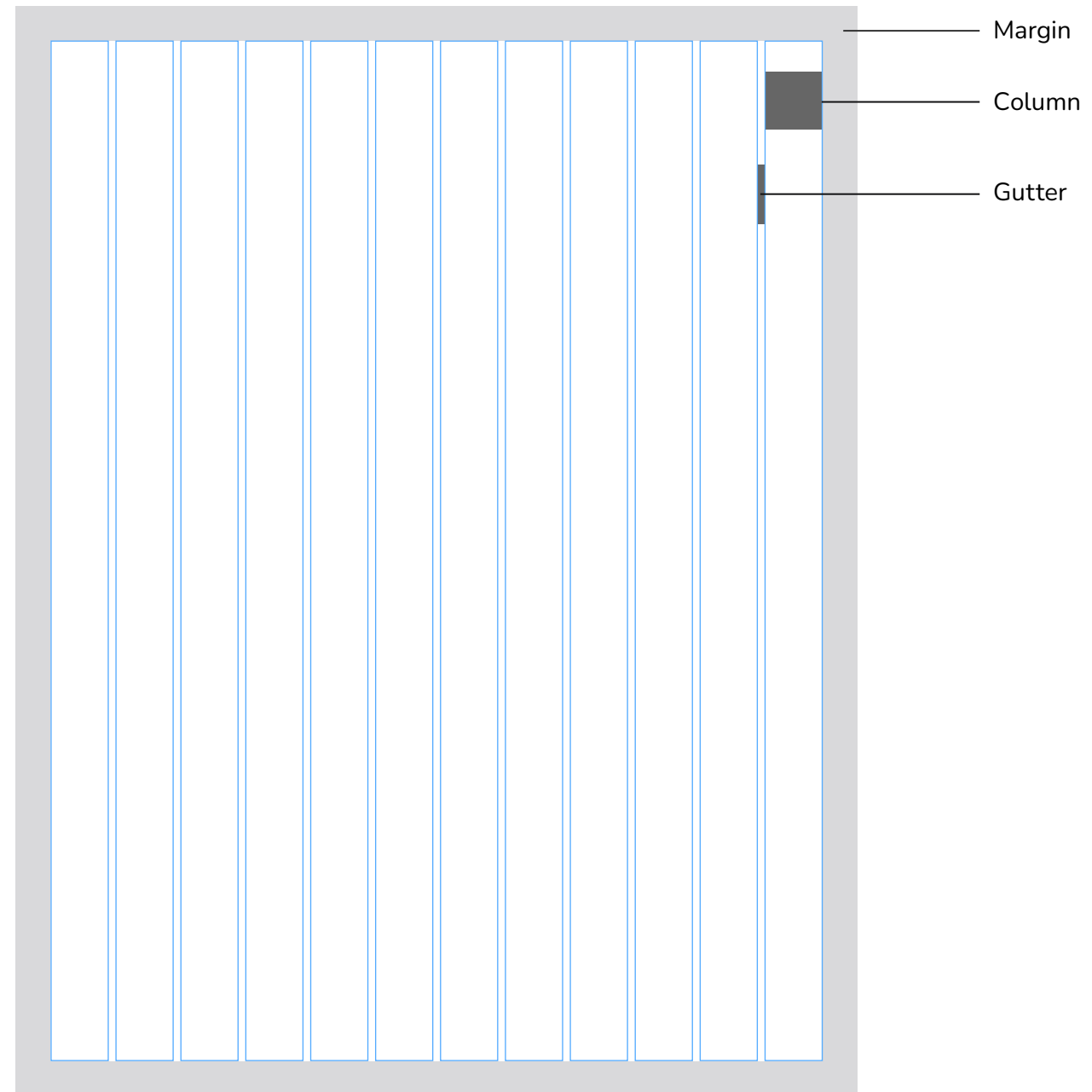

Vertical Layouts

We use a 12-column structure for vertical layouts.

Margin Specifications

Margins will be variable depending on the specifications and print constraints, but whenever possible, margins should have a width $\frac{1}{20}$ of the width of the document.

Gutter Specifications

The gutters between columns should have a width $\frac{1}{75}$ of the width of the document.

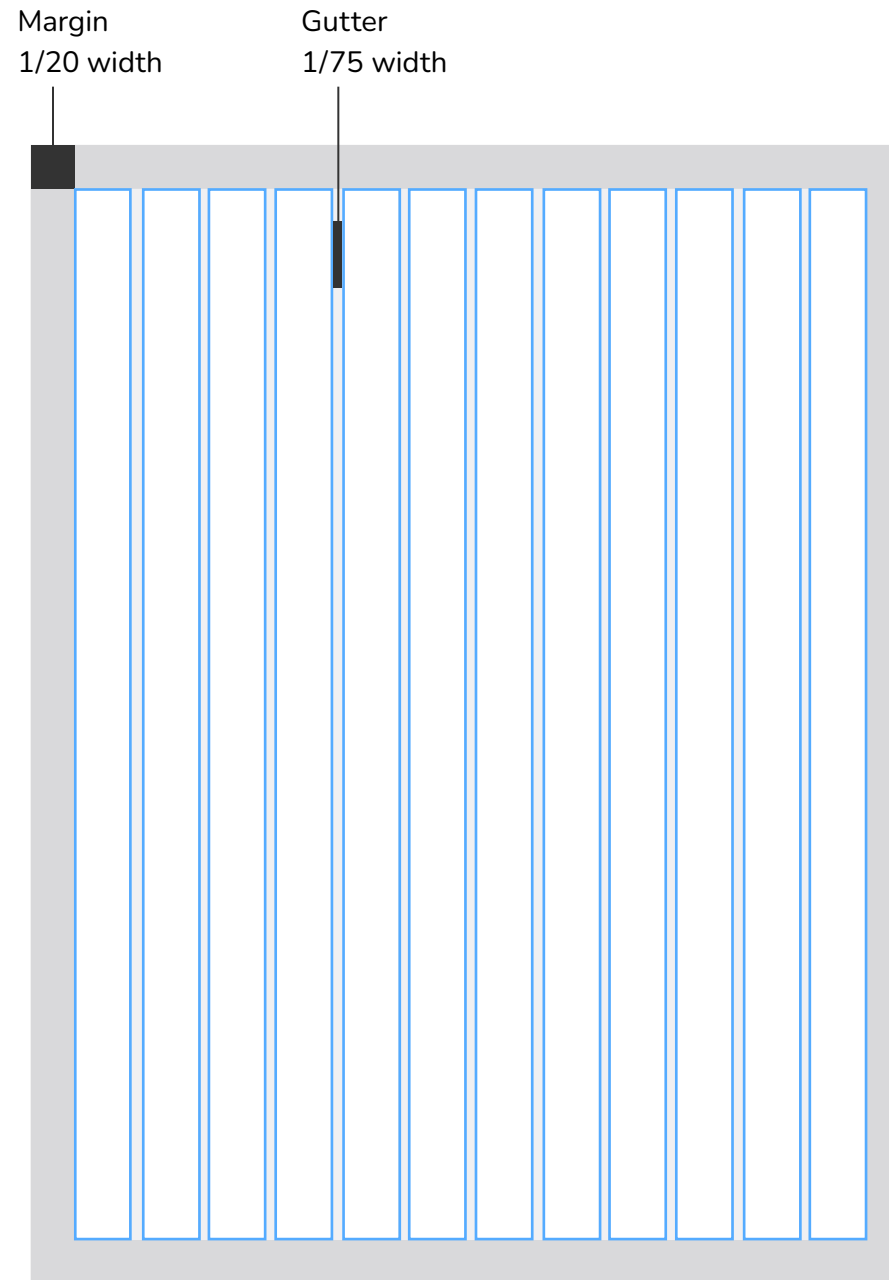

Size: 8.5" x 11"

**Please note that the layout to the right are for demonstration purposes only and have not been drawn to scale.*

Horizontal Layouts

We use a 15-column structure for horizontal layouts.

Margin Specifications

Margins will be variable depending on the specifications and print constraints, but whenever possible, margins should have a width $1/25$ of the width of the document.

Gutter Specifications

The gutters between columns should have a width $1/100$ of the width of the document.

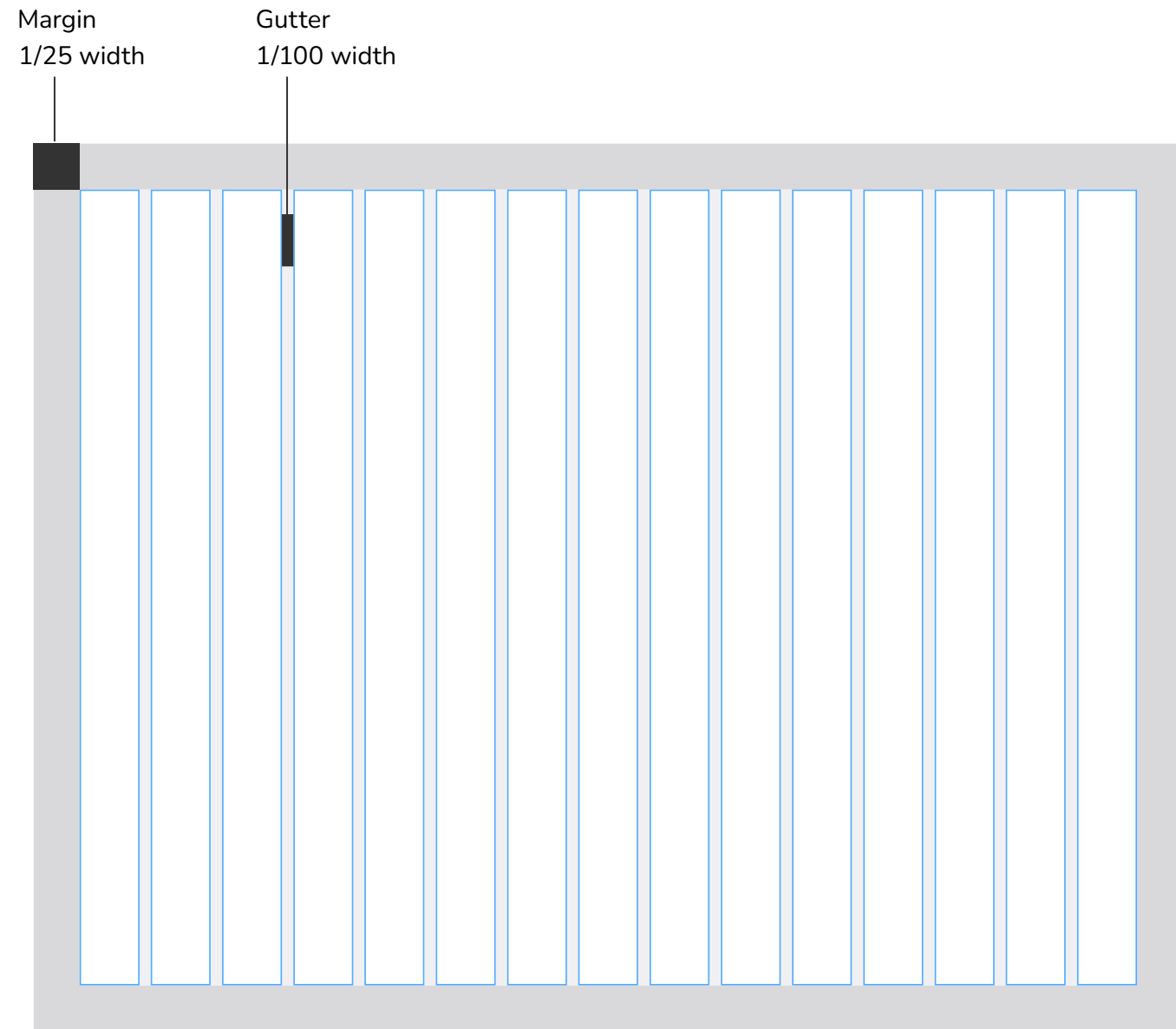

Size: 11" x 8.5"

**Please note that the layouts to the right are for demonstration purposes only and have not been drawn to scale.*

Flexible Grid

As a consistent starting point, use a 12-column grid for vertical layouts and a 15-column grid for horizontal layouts. These allow for flexibility in layout ratios as they can be easily divided. The 12-column easily divides into quarters, thirds, or sixths. The 15-column divides into thirds or fifths.

This grid structure can be used on any rectangular format, such as a letter-sized paper, a mobile phone, or a social media post.

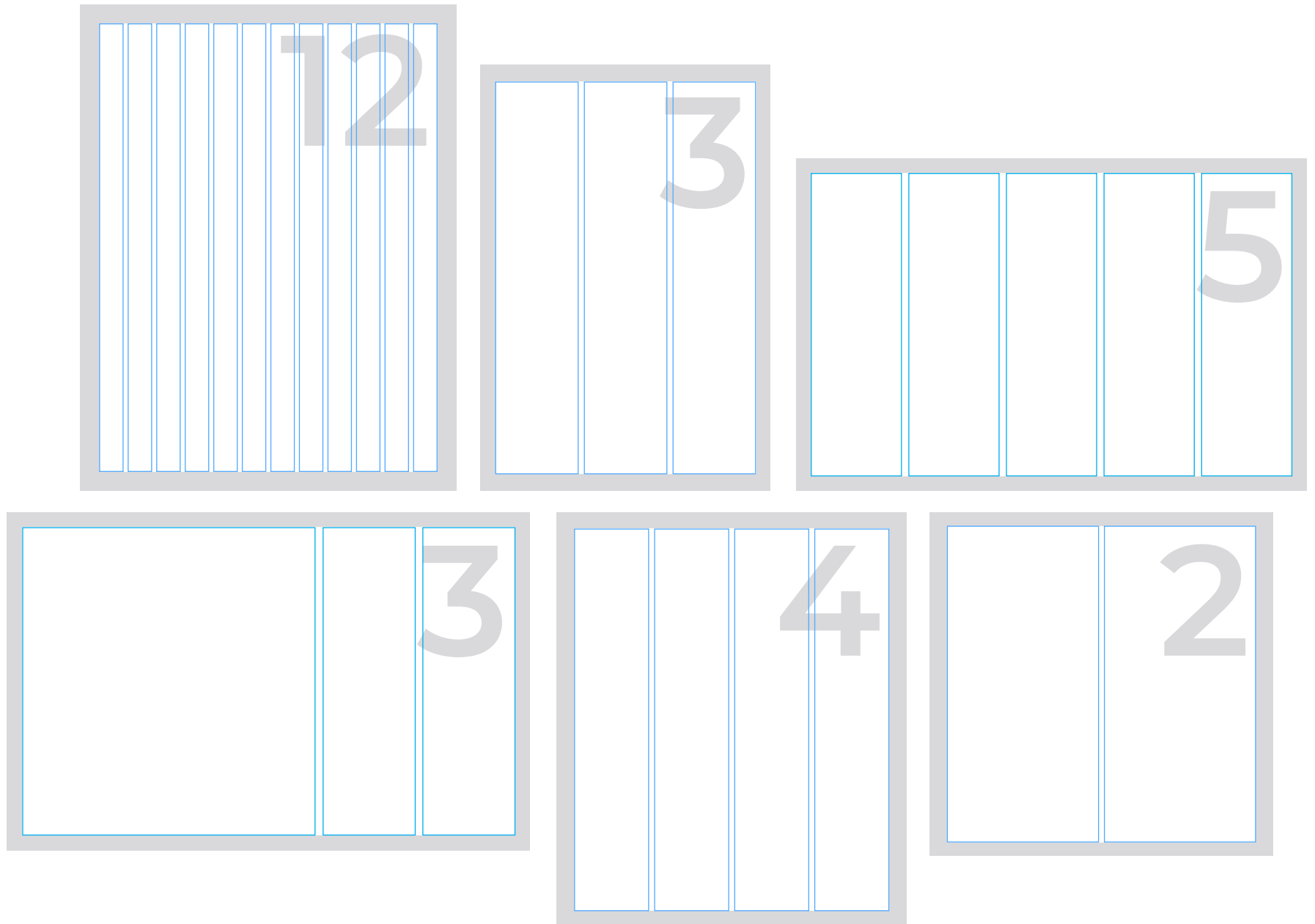

**Please note that the layouts to the right are for demonstration purposes only and have not been drawn to scale.*

Sizing the Logo: Vertical Layouts

The size of the layout area will determine the size of the logo. A consistently proportional scaling of our logo across all of our designs helps create a cohesive look across communications.

After drawing the 12-column grid in a vertical layout, size our logo to span the width of 3 columns.

Even when the layout is divided into fewer columns, the logo should be the width of three columns in the 12-column grid.

When using a co-branded logo lockup, whichever logo is on the LEFT side, should span 3 columns while the logo on the right stays proportionate within the lockup.

**Please note that the layouts to the right are for demonstration purposes only and have not been drawn to scale.*

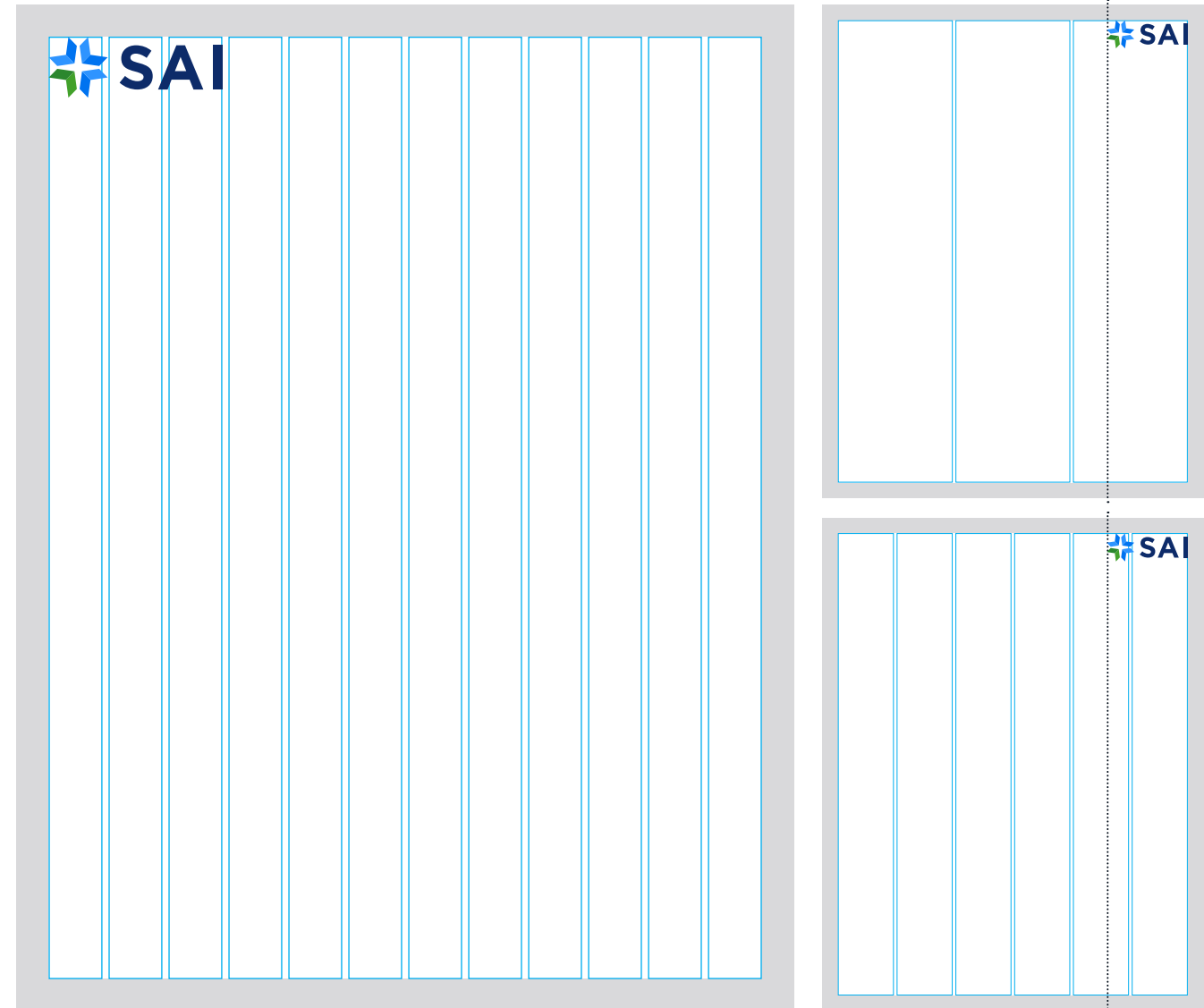

Size: 8.5" x 11"

GRID + LAYOUTS

Sizing the Logo: Horizontal Layouts

The size of the layout area will determine the size of the logo. A consistently proportional scaling of our logo across all of our designs helps create a cohesive look across all communications.

After drawing the 15-column grid in a horizontal layout, size our logo to span the width of two columns.

Even when the layout is divided into fewer columns, the logo should be the width of two columns in the 15-column grid.

When using a co-branded logo lockup, whichever logo is on the LEFT side, should span 2 columns while the logo on the right stays proportionate within the lockup.

**Please note that the layouts to the right are for demonstration purposes only and have not been drawn to scale.*

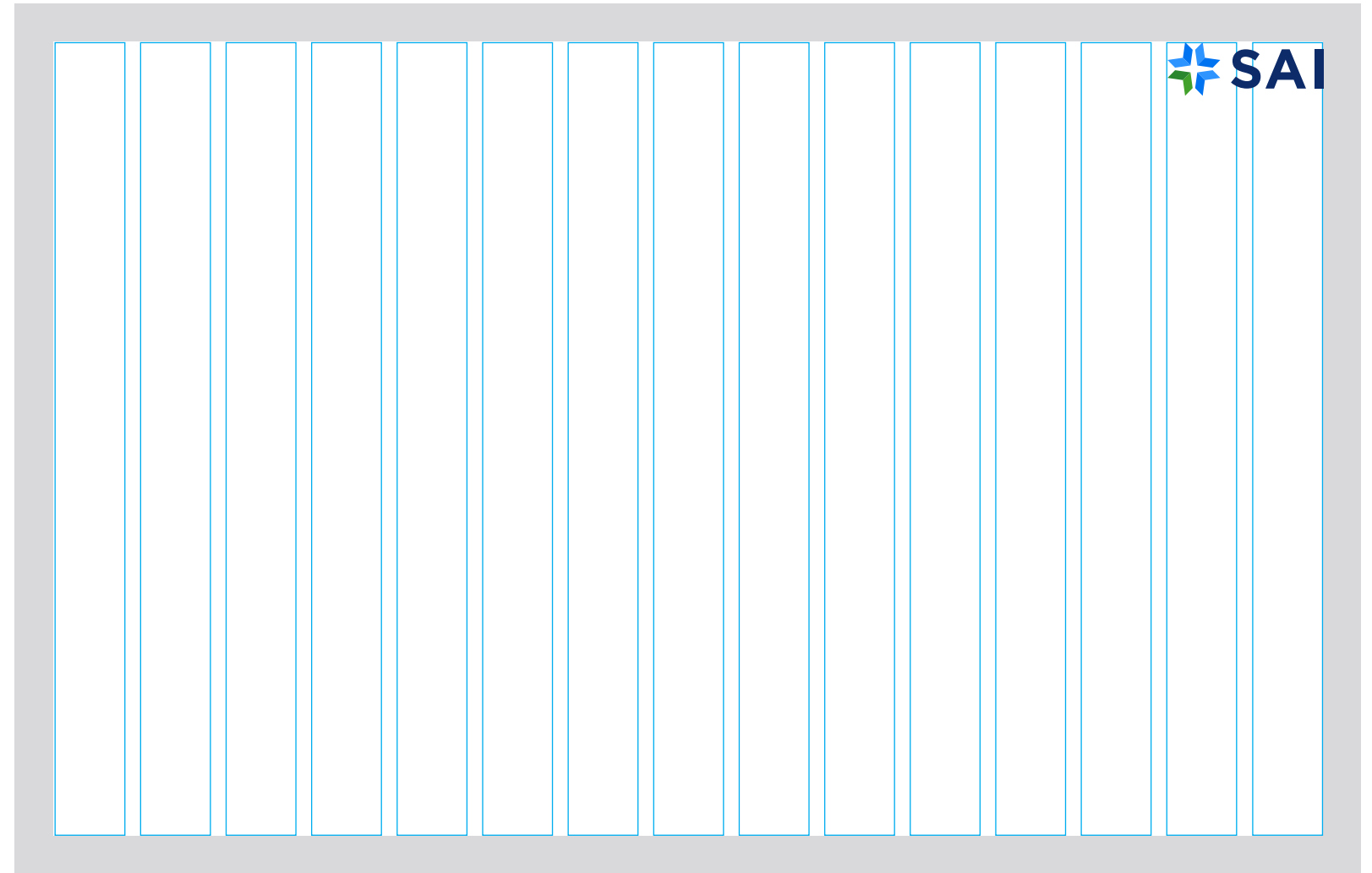

Size: 17" x 11"

GRID + LAYOUTS

Sizing the Logo Without a Grid

When you are not able to construct or reference a grid to guide the sizing of the logo, please follow these instructions:

Vertical Layouts

The logo should be approximately 20% the width of the overall layout size.

Horizontal Layouts

The logo should be approximately 15% the width of the overall layout size.

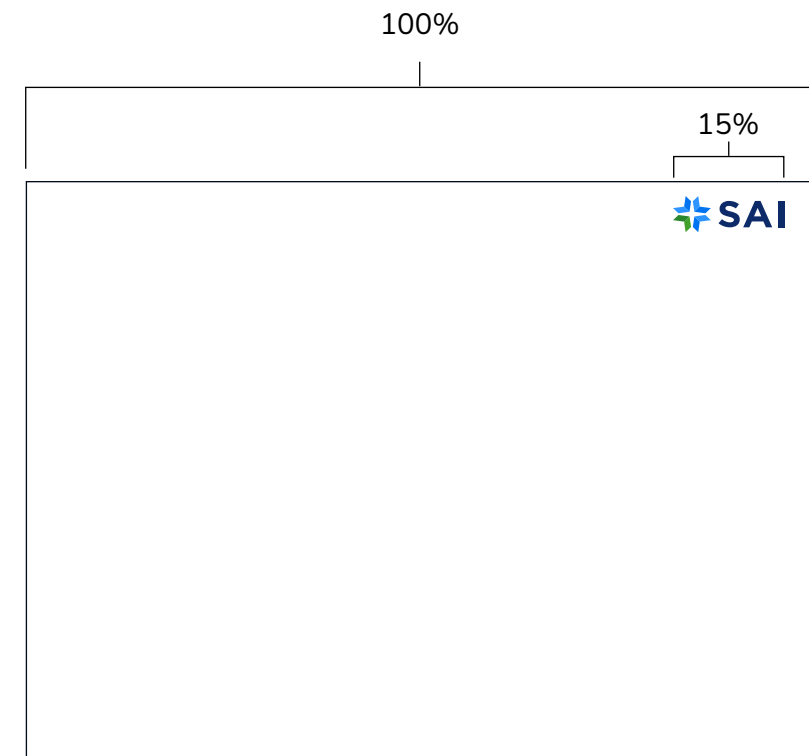

**Please note that the layouts to the right are for demonstration purposes only and have not been drawn to scale.*

GRID + LAYOUTS

Logo Placement

The placement of our logo is an important part of maintaining our brand identity. When using our logo, be sure to place it in a way that ties the piece together and communicates ownership over the message and visuals.

To maintain a more consistent overall result, we have certain preferences regarding where the logo may be placed.

Our preferred placement is in the upper-left or upper-right corners of the layout. However, the logo may be placed in the bottom corners if needed.

The logo should never be placed in the center or the interior of a layout.

**Please note that the layout to the right are for demonstration purposes only and have not been drawn to scale.*

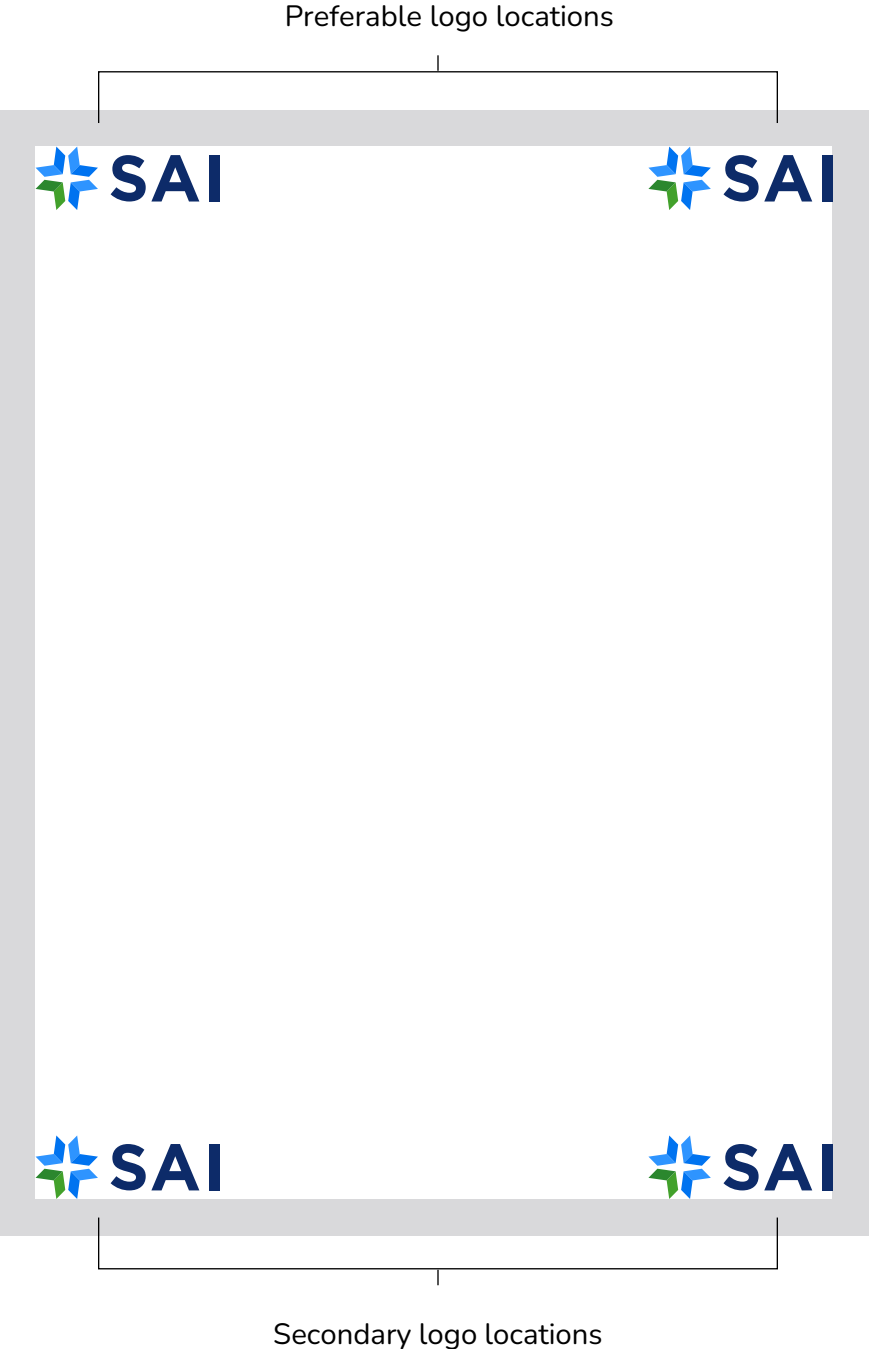

Size: 8.5" x 11"

Type Placement

The grid helps guide the positioning of text and offers flexibility for diverse arrangements while keeping designs organized, easy to read, and professional.

Type should always begin against a grid column. When setting columns of body copy, allow the text to fit within the grid columns. Don't position the text in the middle of grid columns or in a way that otherwise does not align with the grid.

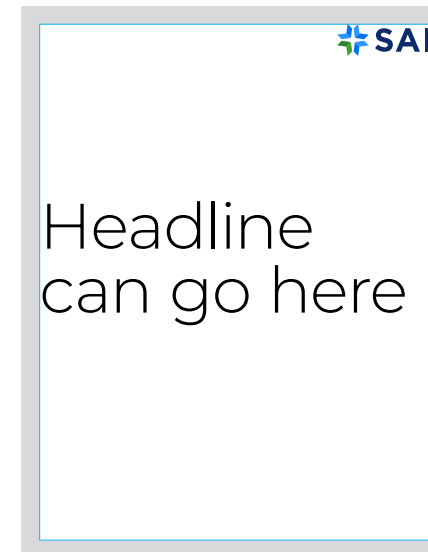
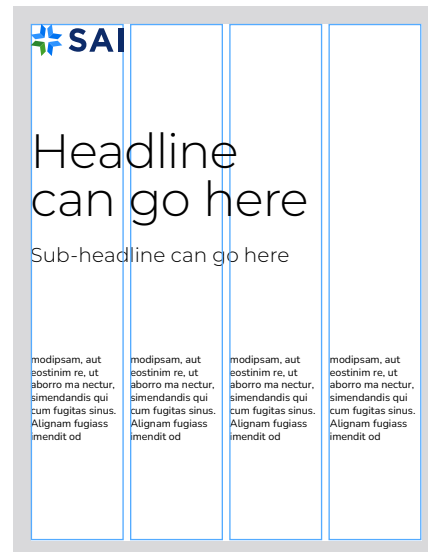
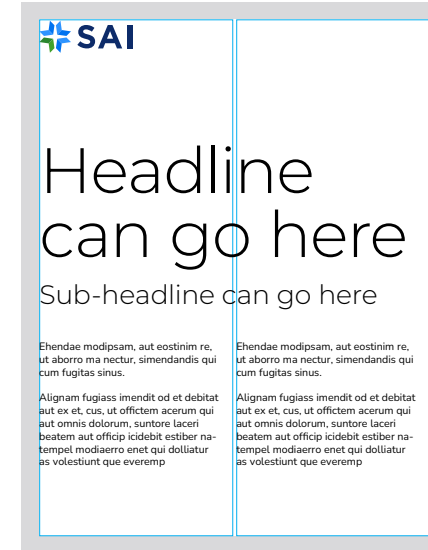
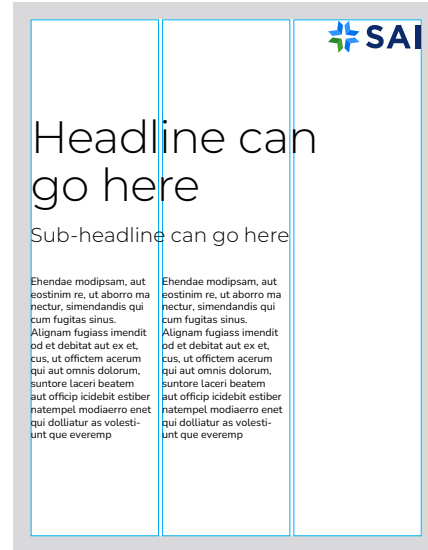

**Please note that the layouts to the right are for demonstration purposes only and have not been drawn to scale.*